

Vortex Series Pumps



Product Selection Guide

Table of Contents

Vortex Series

Vortex Series Curves.....	3
Vortex Series Capabilities.....	4
Design Advantages	5

Vertical Pumps

V2x2-8SE.....	6-7
V2x2-10SE.....	8-9
V2x3-13SE.....	10-11
V3x3-103SE.....	12-13
V3x4-13SE.....	14-15
V4x6-13SE.....	16-17
V6x8-15SE.....	18-19

Horizontal Pumps

V2x2-8SE.....	20-21
V2x2-10SE.....	22-23
V2x3-13SE.....	24-25
V3x3-10SE.....	26-27
V3x4-13SE.....	28-29
V4x6-13SE.....	30-31
V6x8-15SE.....	32-33
V11019-AH-SE.....	34-35

Vortex Series Curves

Vertical and Horizontal Pumps

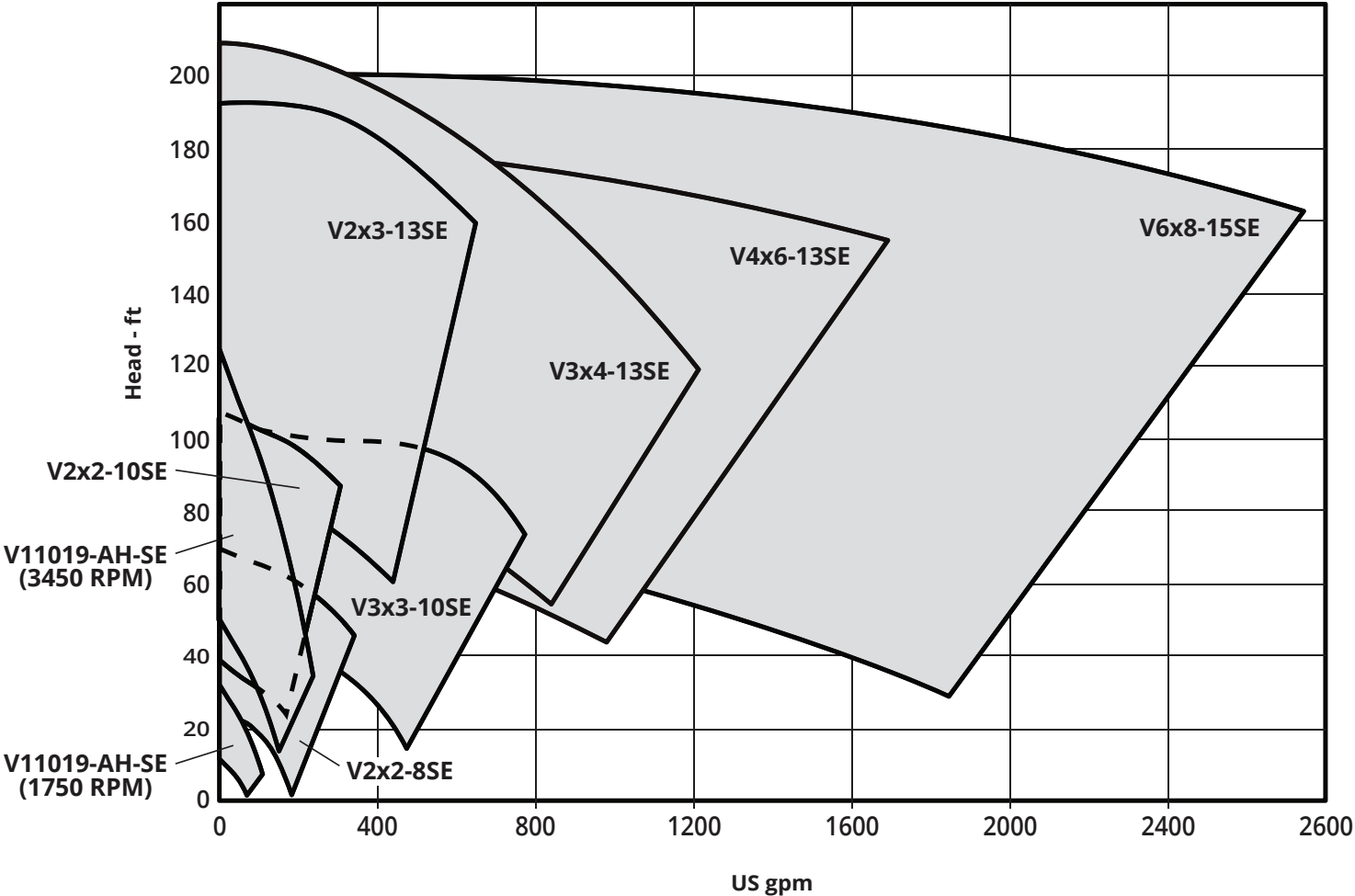

Vortex Series Capabilities

Capacities up to 2,400 | Pressures up to 220'

Gusher Vortex Series Pumps provide years of trouble-free, low maintenance operation in applications with high levels of solids or entrained air.

Vortex pumps handle solids and fibrous materials without clogging. Their design moves liquids and oils containing up to 30% entrained air with no adverse effects on suction performance. Low flows are not a problem for Vortex pumps, as the design allowsthrottling to a low performance range unacceptable to many centrifugal pumps.



Vortex Series Features

- Recessed impeller handles solids and fibrous material without clogging
- Durable CD4MCu impeller standard to prevent premature wear (excludes V11019-AHSE)
- Choice of materials for process chemical compatibility
- Renewable shaft sleeves and bushings protect shaft from wear
- VFD compatible motors to suit application needs
- Power frame and spare wear parts interchangeable with Gusher 7550 and 7071 Series pumps to streamline replacement part inventory

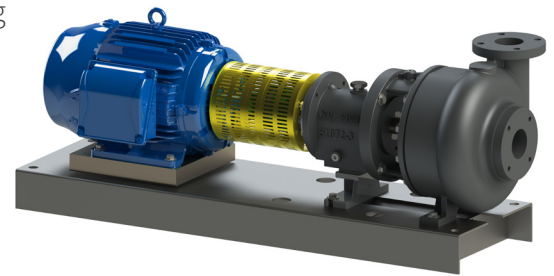

Vortex Series Options

- Cast Iron, Ductile Iron, 316 Stainless Steel, CD4MCu construction
- Carbon or Tungsten Carbide bushings (vertical models)
- Extended lengths (vertical models)
- Flush line addition
- Top pullout design (vertical models; on standard, +6 & +12 lengths only; subject to Gusher Engineering approval)
- Multiple mechanical seal materials

Applications

- Agriculture
- Fibrous Waste
- Sludge
- Wastewater and water purification
- Shavings
- Swarf
- Paper Pulp

Gusher Pumps Design Advantages

Vortex Clog-free Design

Gusher's Vortex Series is engineered for optimal performance in applications with large diameter solids, fibrous and abrasive materials, and high air entrainment. Designed with much lower radial loading compared to typical centrifugal pumps, Vortex pumps offer more reliable operation with longer service life in challenging environments. The Vortex design allows a wider range of operation, including low flows that are unacceptable in standard centrifugal pumps.

Benefits

- Design tolerates operation at close to dead head, ideally suited to applications where flow varies greatly
- Low radial loads minimize shaft deflection, reducing parts wear
- In horizontal or submersible installation, the reduced shaft movement significantly extends seal life
- In a vertical installation, low shaft deflection allows full cantilever design with no contacting surfaces below bearing housing
- Non-clog, semi-open impeller passes fibrous material and solids equal to the size of the discharge without breaking up
- Recessed impeller handles liquids with up to 30% air entrainment
- Durable CDMCu impeller construction withstands even abrasive solids, extending service life

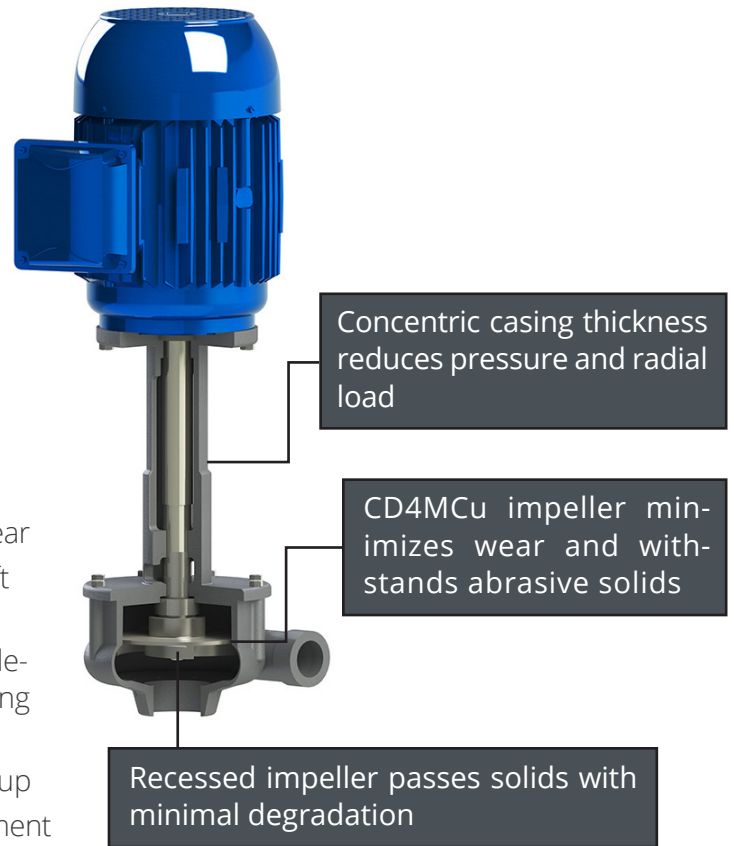

Back Pullout Design Option

Routine maintenance is critical to keeping all process equipment running at peak performance. While necessary, preventative work carries a cost in both man hours and loss of production during service. Gusher's Back Pullout Design Standard on horizontal vortex models minimizes these costs by cutting down overall repair time.

Rather than disconnecting piping and uninstalling the entire pump, this design allows just the rotating elements to be removed, while the casing and inlet and discharge pipe remain in place. Once the pump is serviced (typically replacement of the seal assembly or shaft sleeve) the pump is quickly returned to service.

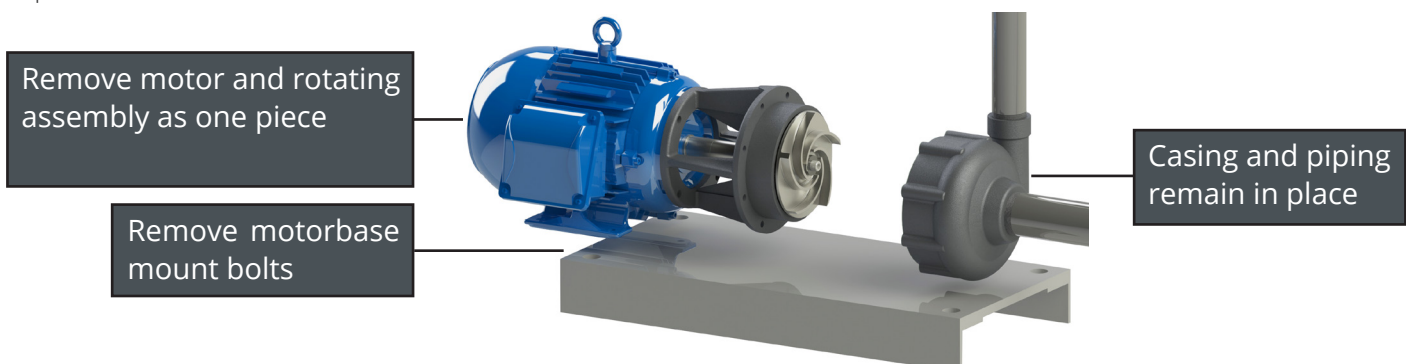

V2X2-8SE

Key Specifications

- Flow:** Up to 320 gpm (1750 RPM)
- Head:** Up to 70' TDH (1750 RPM)
- Liquid Temp:** Max 180° F
- Power Options:** 1.5 hp, 2 hp, 3 hp, 5 hp, 7.5 hp and 10 hp
- Power Frame:** 52 VHD
- Motor Type:** TEFC, TC Frame
- Max Solid Size:** 2"
- Intake:** 2"
- Discharge:** 2"

Model-Specific Options

- Cast Iron or 316 Stainless construction
- Extended shafts (6", 12", 18" or 24" standard; custom available, consult engineering)



Dimensions*

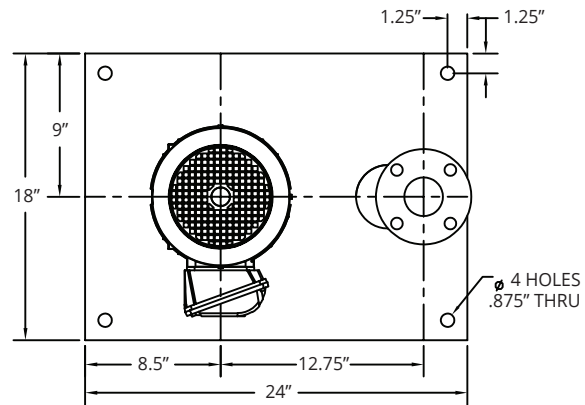
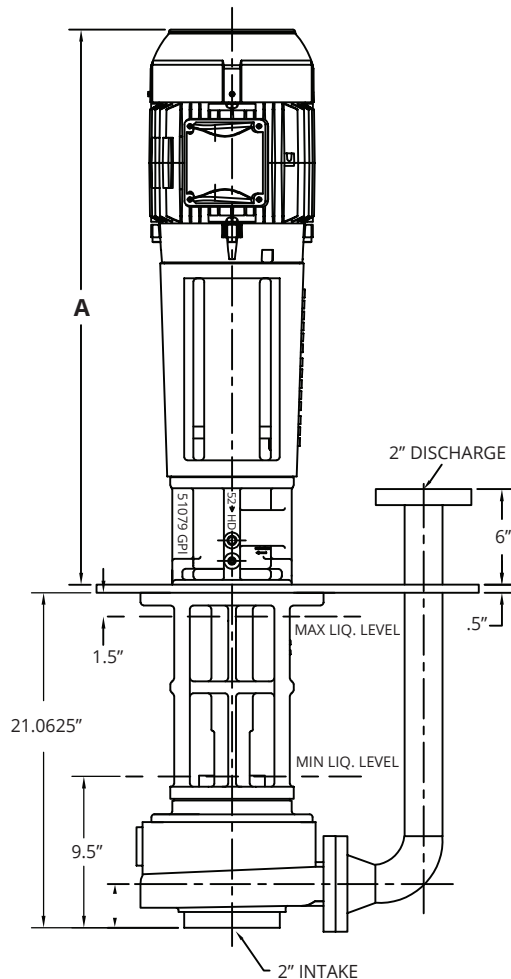

1750 RPM

HP	NEMA Motor Frame Size	Above Plate Length (A)	Weight (lbs)
1.5	143TC	29.75"	480
2	145TC	29.75"	480
3	182TC	33.125"	525
5	184TC	33.25"	530
7.5	213TC	33.25"	600
10	215TC	36.375"	605

*For reference only; not for construction. Contact Gusher Engineering for certified drawings.

Performance Curve

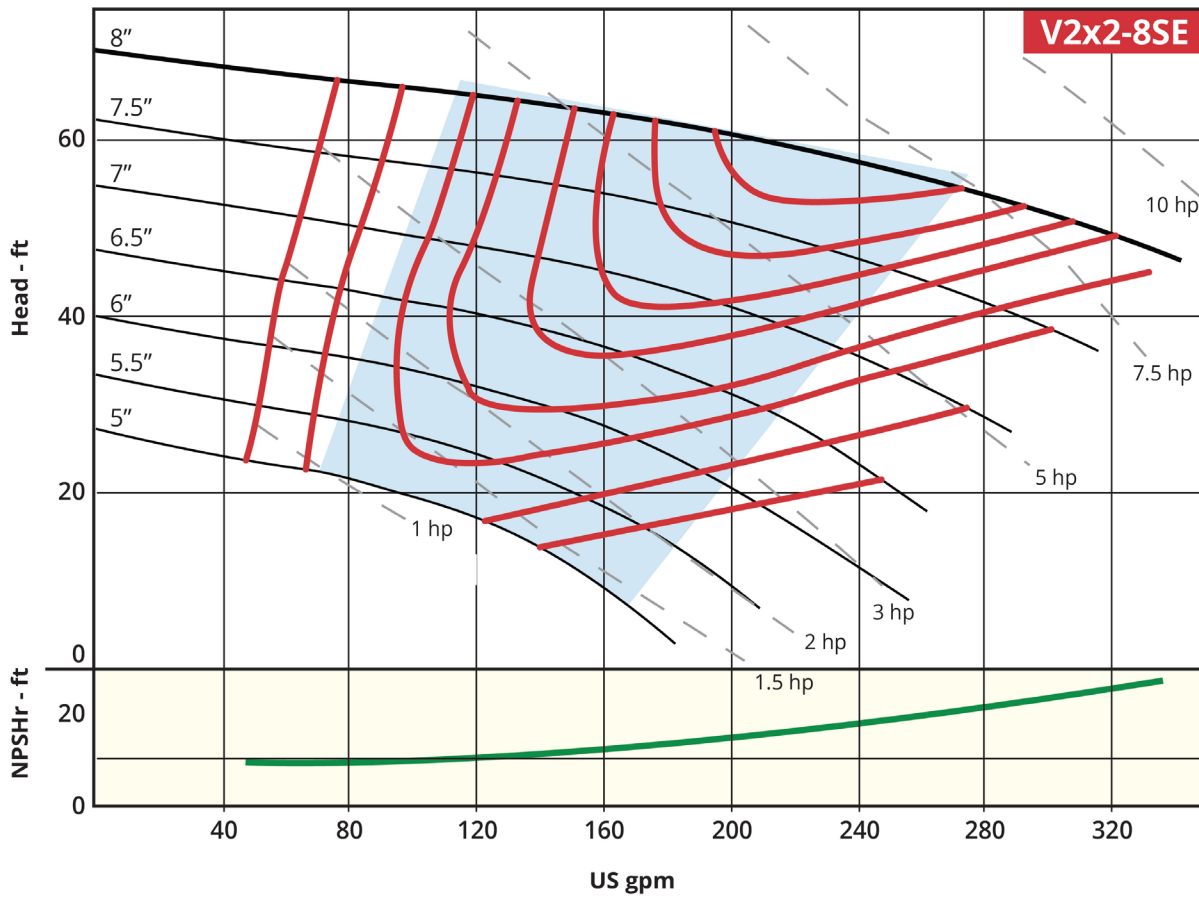

VERTICAL MODELS

Recommended Operating Range

V2X2-10SE

Key Specifications

- Flow:** Up to 360 gpm (1750 RPM)
- Head:** Up to 110' TDH (1750 RPM)
- Liquid Temp:** Max 180° F
- Power Options:** 3 hp, 5 hp, 7.5 hp, 10 hp and 15 hp
- Power Frame:** 52 VHD
- Motor Type:** TEFC, TC Frame
- Max Solid Size:** 2"
- Intake:** 2"
- Discharge:** 2"

Model-Specific Options

- Cast Iron or 316 Stainless construction
- Extended shafts (6", 12", 18" or 24" standard; custom available, consult engineering)



Dimensions*

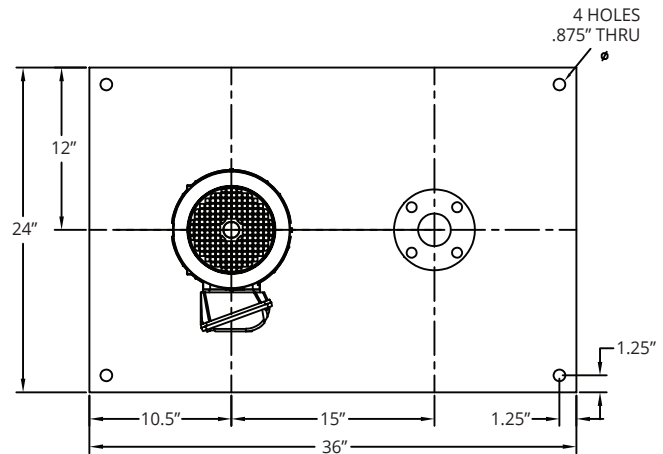
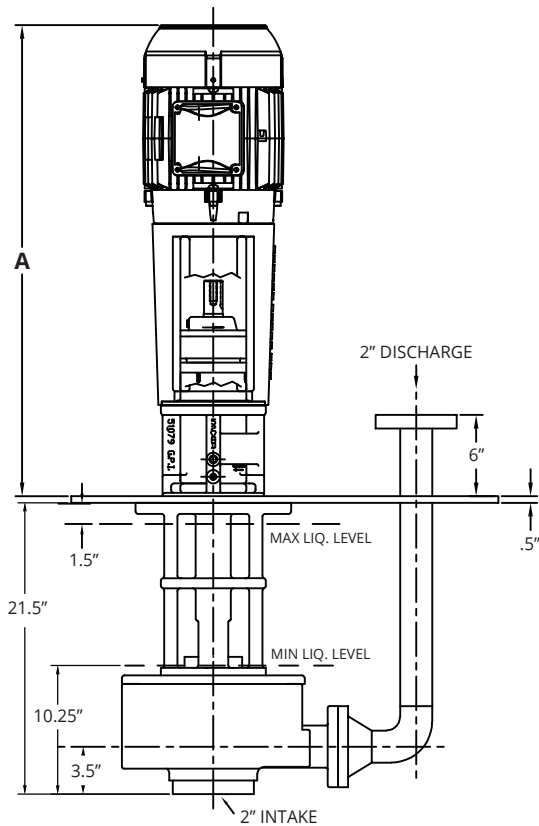

1750 RPM

HP	NEMA Motor Frame Size	Above Plate Length (A)	Weight (lbs)
3	182TC	33.125"	530
5	184TC	33.25"	530
7.5	213TC	33.25"	575
10	215TC	33.375"	580
15	254TC	36.50"	765

*For reference only; not for construction. Contact Gusher Engineering for certified drawings.

Performance Curve

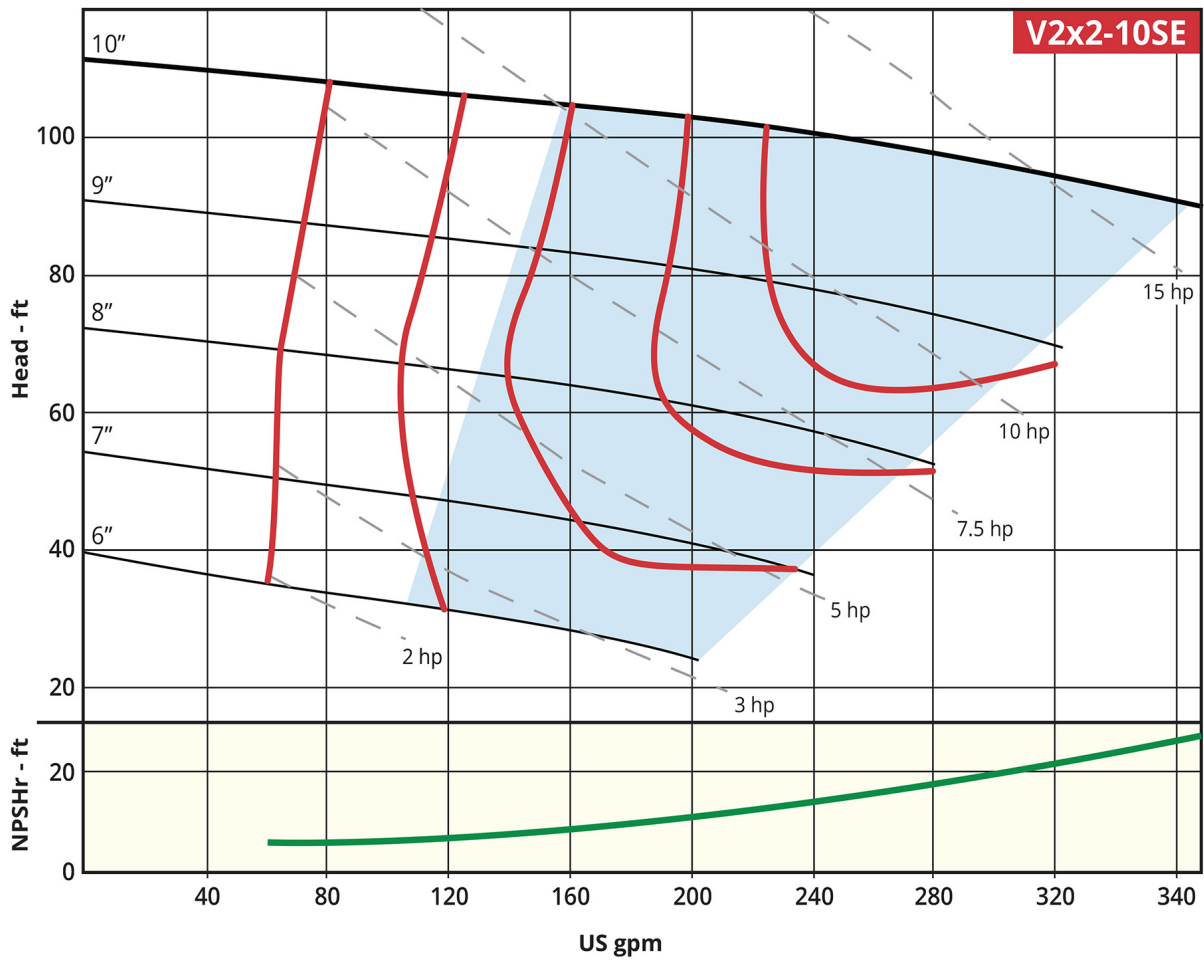

VERTICAL MODELS

Recommended Operating Range

V2X3-13SE

Key Specifications

- Flow:** Up to 620 gpm (1750 RPM)
- Head:** Up to 200' TDH (1750 RPM)
- Liquid Temp:** Max 180° F
- Power Options:** 15 hp, 20 hp, 25 hp, 30 hp, 40 hp and 50 hp
- Power Frame:** 52 VHD
- Motor Type:** TEFC, TC Frame
- Max Solid Size:** 2"
- Intake:** 3"
- Discharge:** 2"

Model-Specific Options

- Cast Iron or 316 Stainless construction
- Extended shafts (6", 12", 18" or 24" standard; custom available, consult engineering)



Dimensions*

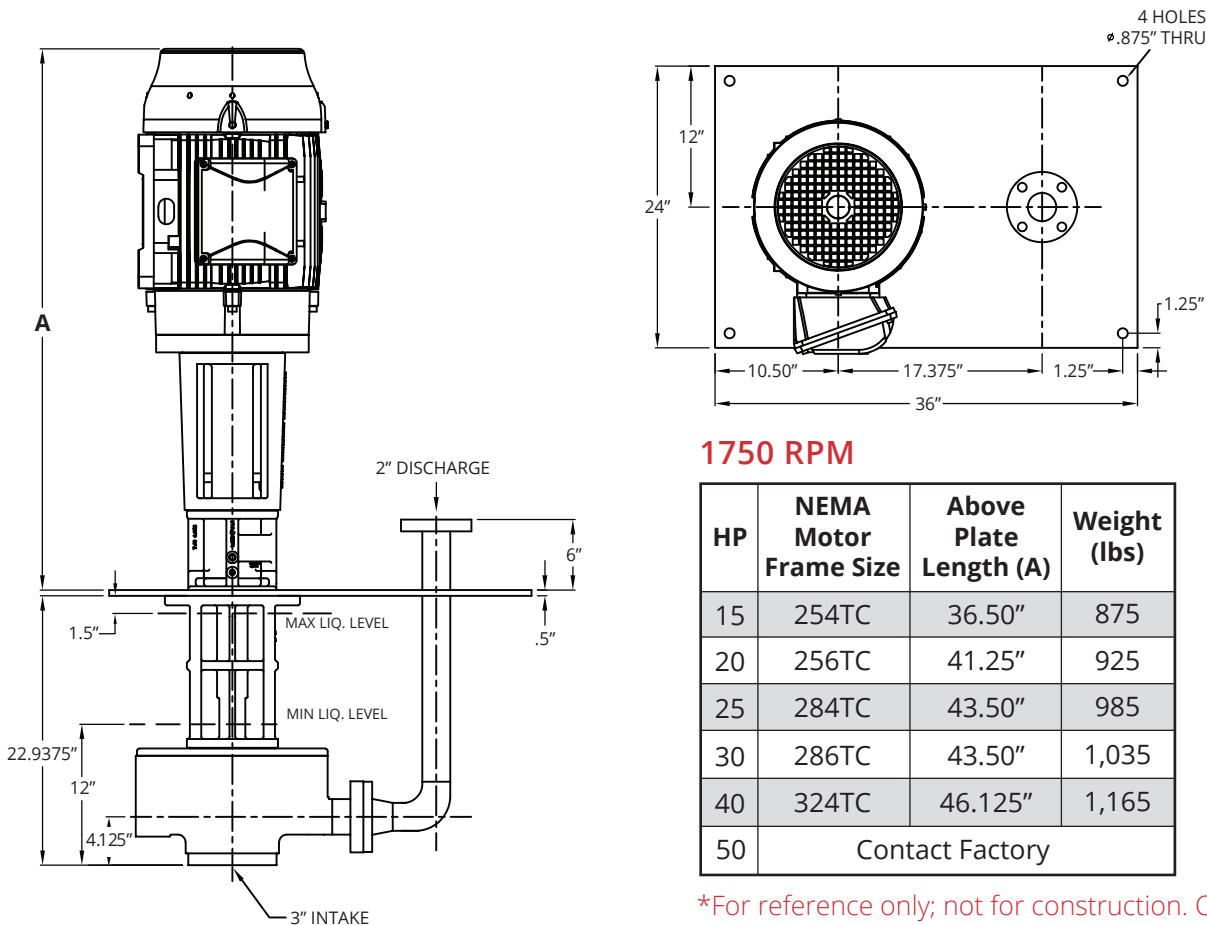

1750 RPM

HP	NEMA Motor Frame Size	Above Plate Length (A)	Weight (lbs)
15	254TC	36.50"	875
20	256TC	41.25"	925
25	284TC	43.50"	985
30	286TC	43.50"	1,035
40	324TC	46.125"	1,165
50	Contact Factory		

*For reference only; not for construction. Contact Gusher Engineering for certified drawings.

Performance Curve

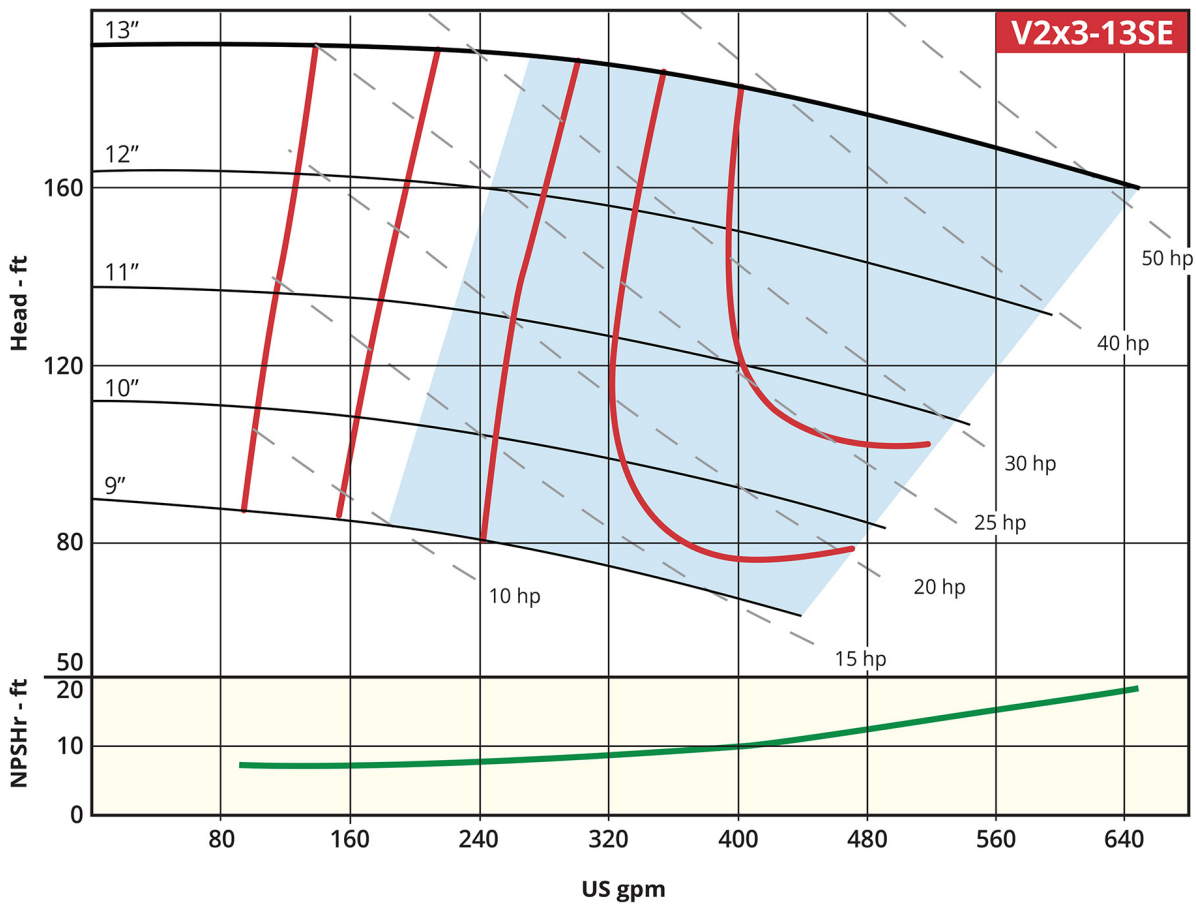

VERTICAL MODELS

Recommended Operating Range

V3X3-10SE

Key Specifications

Flow: Up to 760 gpm (1750 RPM)

Head: Up to 110' TDH (1750 RPM)

Liquid Temp: Max 180° F

Power Options: 7.5 hp, 10 hp, 15 hp, 20 hp, 25 hp, 30 hp and 40 hp

Power Frame: 52 VHD

Motor Type: TEFC, TC Frame

Max Solid Size: 3"

Intake: 3"

Discharge: 3"



Model-Specific Options

- Cast Iron or 316 Stainless construction
- Extended shafts (6", 12", 18" or 24" standard; custom available, consult engineering)

Dimensions*

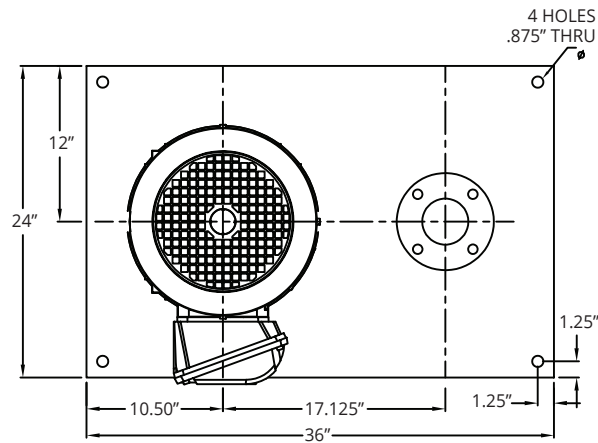
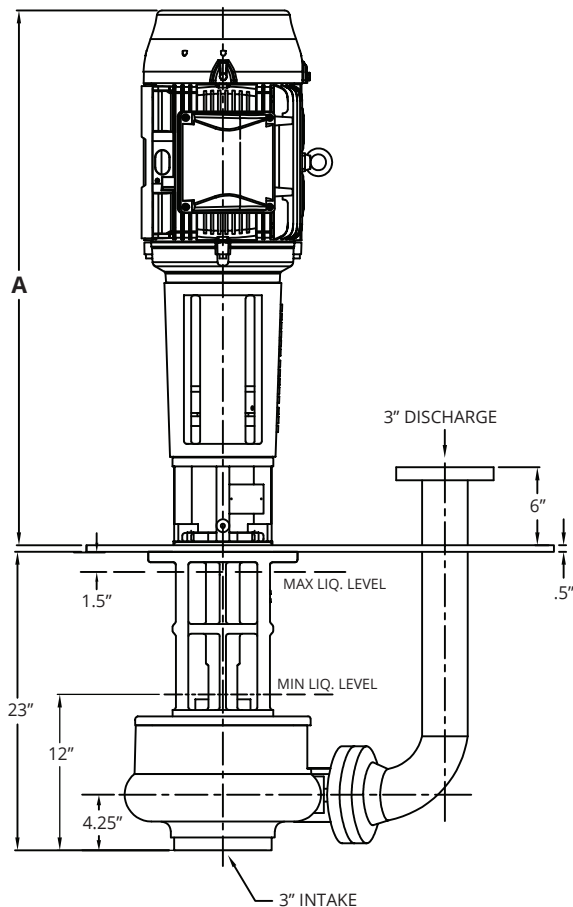

1750 RPM

HP	NEMA Motor Frame Size	Above Plate Length (A)	Weight (lbs)
7.5	213TC	33.25"	625
10	215TC	36.375"	630
15	254TC	36.50"	815
20	256TC	41.25"	865
25	284TC	43.50"	925
30	286TC	43.50"	975
40	324TC	46.125"	1,105

*For reference only; not for construction. Contact Gusher Engineering for certified drawings.

Performance Curve

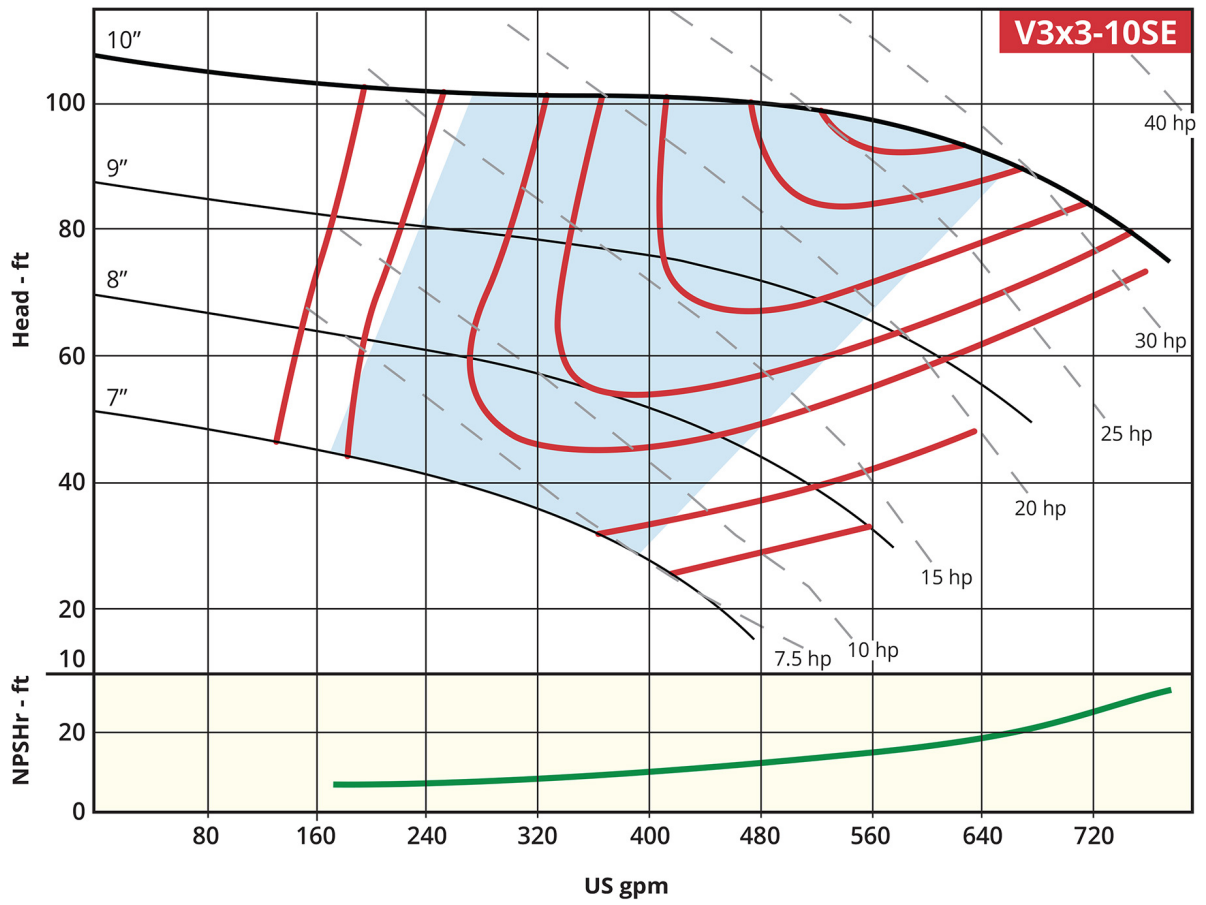

VERTICAL MODELS

Recommended Operating Range

V3X4-13SE

Key Specifications

- Flow:** Up to 1,150 gpm (1750 RPM)
- Head:** Up to 210' TDH (1750 RPM)
- Liquid Temp:** Max 180° F
- Power Options:** 30 hp, 40 hp, 50 hp, 60 hp, 75 hp and 100 hp
- Power Frame:** 52, 53 and 54VHD
- Motor Type:** TEFC, TC Frame
- Max Solid Size:** 3"
- Intake:** 4"
- Discharge:** 3"

Model-Specific Options

- Cast Iron or 316 Stainless construction
- Extended shafts (6", 12", 18" or 24" standard; custom available, consult engineering)



Dimensions*

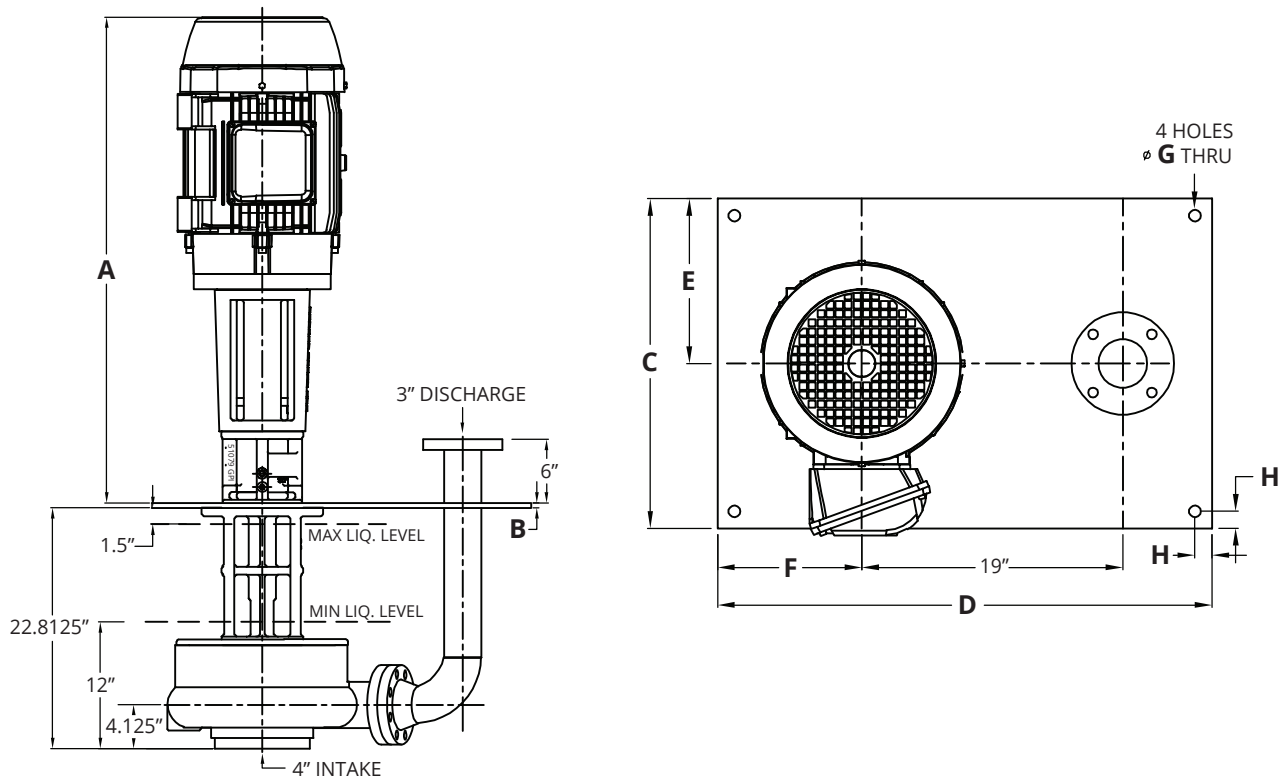

*52 VHD drawing for reference; other power frames may vary slightly

Dimensions cont.

Power Frame	HP	NEMA Motor Frame Size	Above Plate Length (A)	Plate Thickness (B)	Plate Width (C)	Plate Length (D)	Plate Width Edge to Motor Center (E)	Plate Length Edge to Motor Center (F)	Hole Diameter (G)	MTG Hole Offset (H)	Weight (lbs)
52	30	286TC	43.50"	0.50"	24.00"	36.00"	12.00"	10.50"	0.875"	1.25"	1,065
	40	324TC	46.125"	0.50"	24.00"	36.00"	12.00"	10.50"	0.875"	1.25"	1,185
53	50	326TC	56.375"	1.00"	30.00"	42.00"	15.00"	14.00"	1.50"	2.00"	1,650
	60	364TC	59.50"	1.00"	30.00"	42.00"	15.00"	14.00"	1.50"	2.00"	1,920
54	75	365TC	57.875"	1.00"	32.00"	48.00"	16.00"	14.00"	1.50"	2.00"	2,000
	100	Contact Factory									

VERTICAL MODELS

Performance Curve

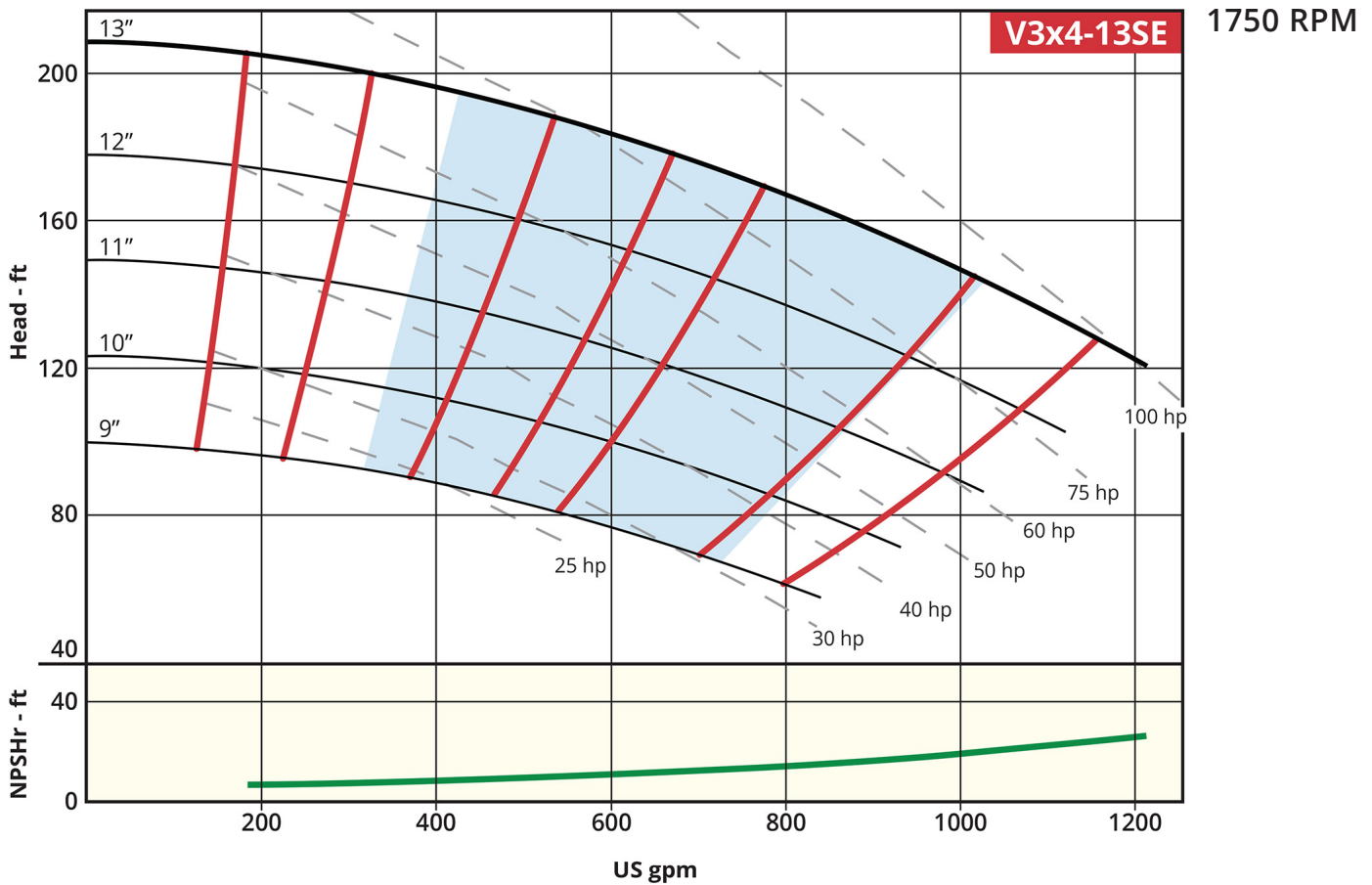

Recommended Operating Range

V4X6-13SE

Key Specifications

- Flow:** Up to 1,500 gpm (1750 RPM)
- Head:** Up to 180' TDH (1750 RPM)
- Liquid Temp:** Max 180° F
- Power Options:** 30 hp, 40 hp, 50 hp, 60 hp, 75 hp and 100 hp
- Power Frame:** 52, 53 and 54VHD
- Motor Type:** TEFC, TC Frame
- Max Solid Size:** 4"
- Intake:** 6"
- Discharge:** 4"

Model-Specific Options

- Cast Iron or 316 Stainless construction
- Extended shafts (6", 12", 18" or 24" standard; custom available, consult engineering)



Dimensions*

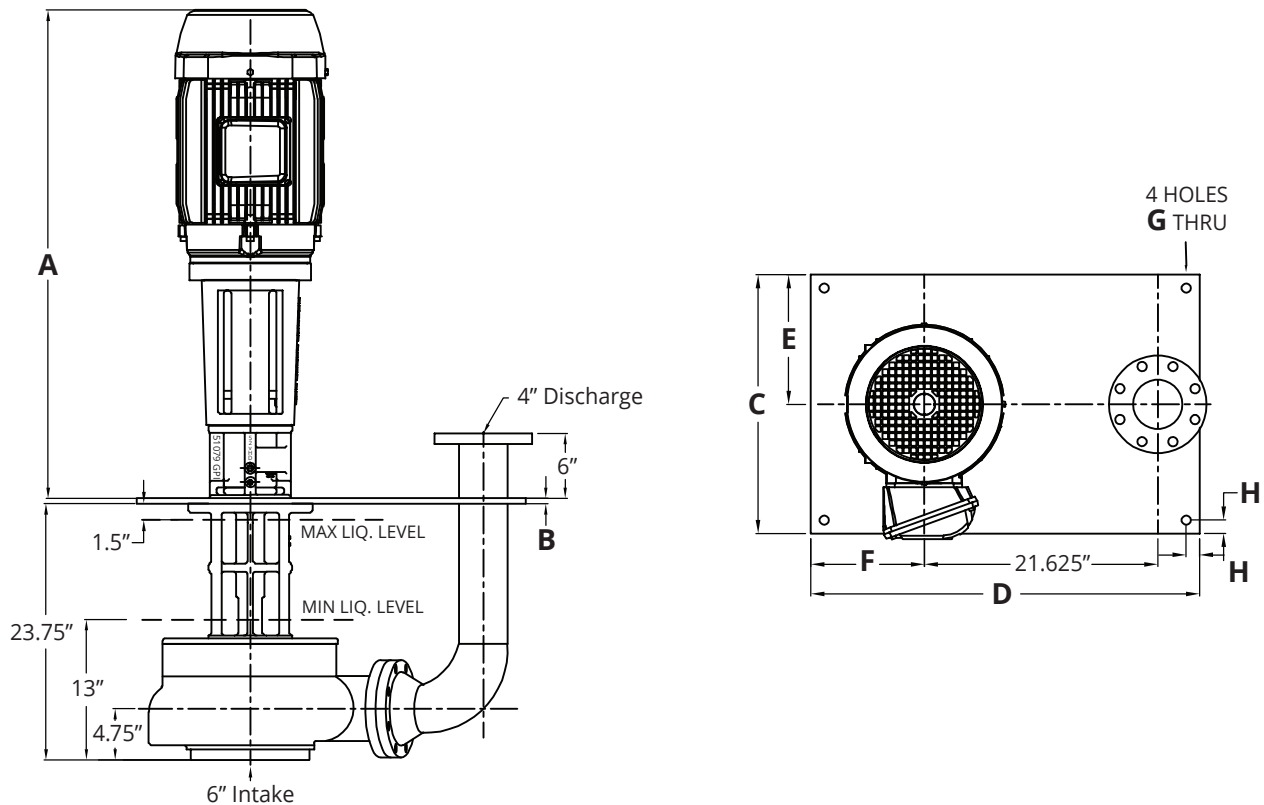

*52 VHD drawing for reference; other power frames may vary slightly

Dimensions cont.

Power Frame	HP	NEMA Motor Frame Size	Above Plate Length (A)	Plate Thickness (B)	Plate Width (C)	Plate Length (D)	Plate Width Edge to Motor Center (E)	Plate Length Edge to Motor Center (F)	Hole Diameter (G)	MTG Hole Offset (H)	Weight (lbs)
52	40	324TC	46.125"	0.50"	24.00"	36.00"	12.00"	10.50"	0.875"	1.25"	1,250
53	50	326TC	56.375"	1.00"	30.00"	42.00"	15.00"	14.00"	1.50"	2.00"	1,850
	60	364TC	59.00"	1.00"	30.00"	42.00"	15.00"	14.00"	1.50"	2.00"	1,975
54	75	365TC	57.875"	1.00"	32.00"	48.00"	15.00"	14.00"	1.50"	2.00"	2,200
	100	405TC	61.875"	1.00"	32.00"	48.00"	15.00"	14.00"	1.50"	2.00"	2,450

VERTICAL MODELS

Performance Curve

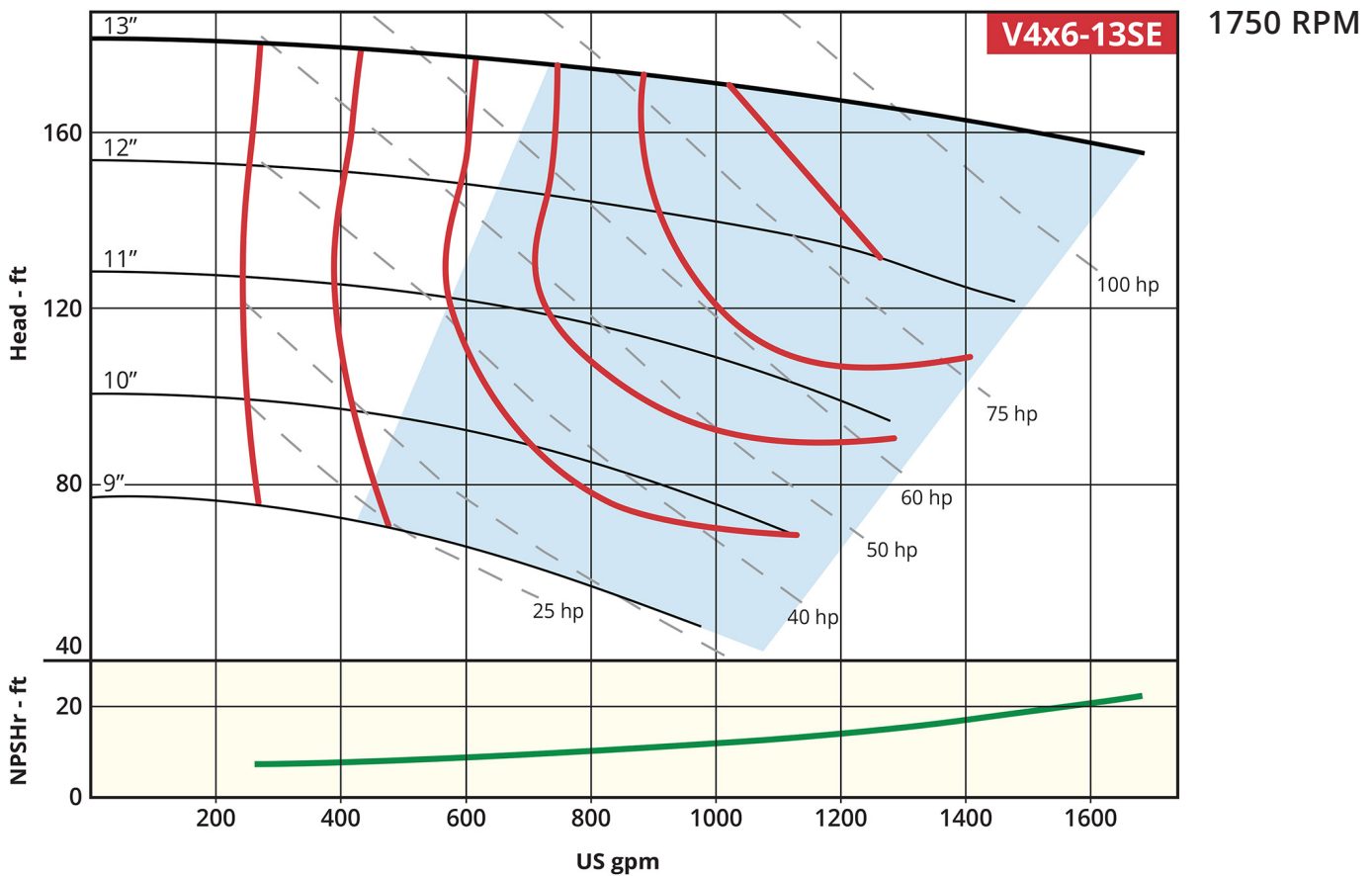

Recommended Operating Range

V6X8-15SE

Key Specifications

- Flow:** Up to 2,400 gpm (1750 RPM)
- Head:** Up to 200' TDH (1750 RPM)
- Liquid Temp:** Max 180° F
- Power Options:** 60 hp, 75 hp, 100 hp, 125 hp, 150 hp and 200 hp
- Power Frame:** 54 VHD
- Motor Type:** TEFC, TC Frame
- Max Solid Size:** 6"
- Intake:** 8"
- Discharge:** 6"

Model-Specific Options

- Cast Iron or 316 Stainless construction
- Extended shafts (6", 12", 18" or 24" standard; custom available, consult engineering)



Dimensions*

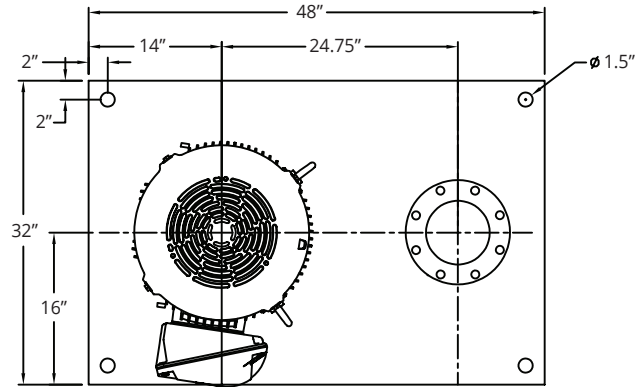
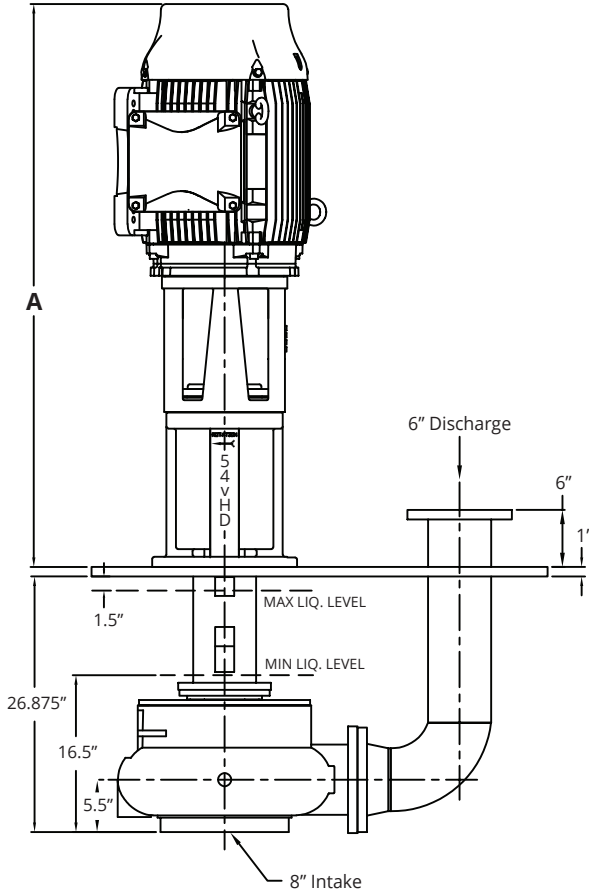

1750 RPM

HP	NEMA Motor Frame Size	Above Plate Length (A)	Weight (lbs)
60	364TC	59.00"	2,650
75	365TC	59.00"	2,725
100	404TC	63.00"	2,970
125	444TC	67.25"	3,350
150	445TC	67.25"	3,595
200	Contact Factory		

*For reference only; not for construction. Contact Gusher Engineering for certified drawings.

Performance Curve

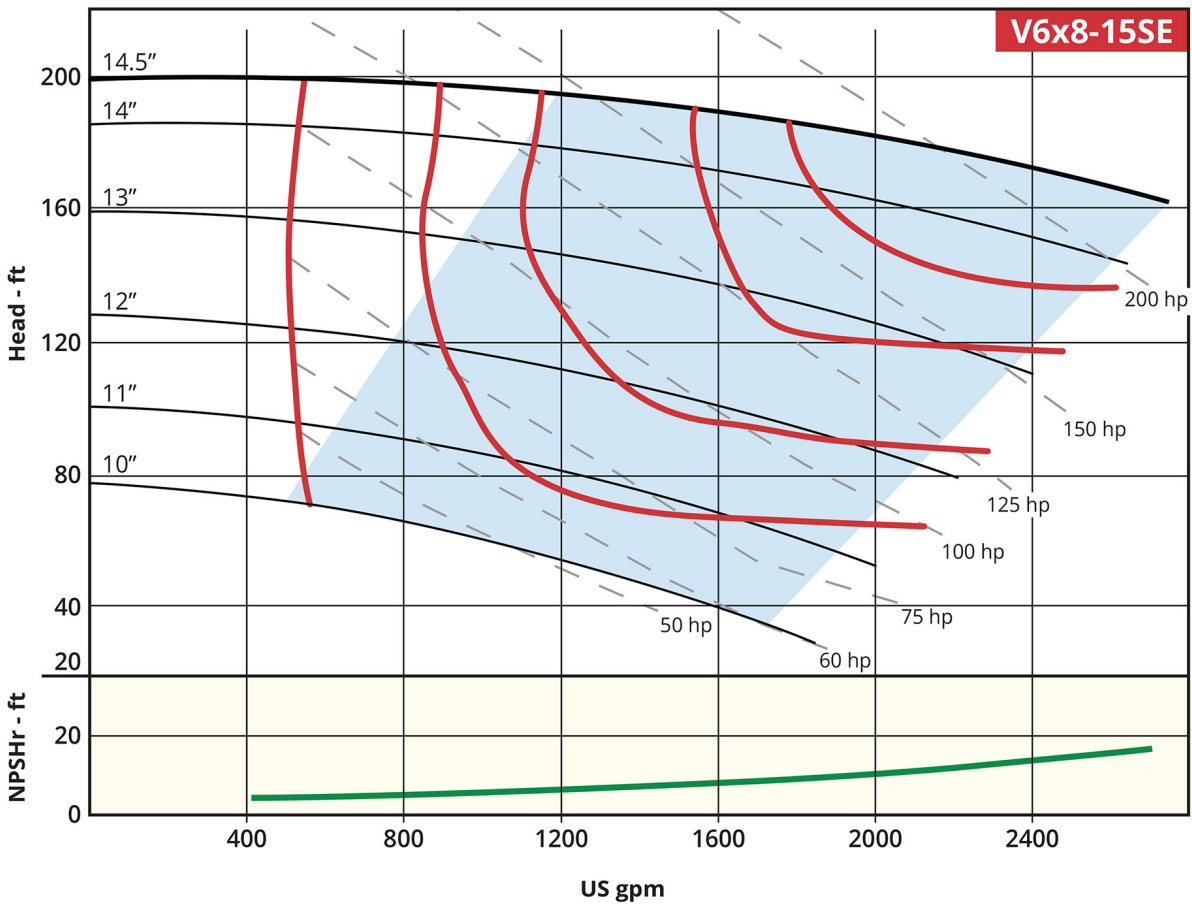

VERTICAL MODELS

Recommended Operating Range

V2x2-8SE

Key Specifications

- Flow:** Up to 320 gpm (1750 RPM)
- Head:** Up to 70' TDH (1750 RPM)
- Liquid Temp:** Max 180° F
- Power Options:** 1.5 hp, 2 hp, 3 hp, 5 hp, 7.5 hp and 10 hp
- Power Frame:** 7071S
- Motor Type:** TEFC, T Frame
- Max Solid Size:** 2"
- Intake:** 2"
- Discharge:** 2"

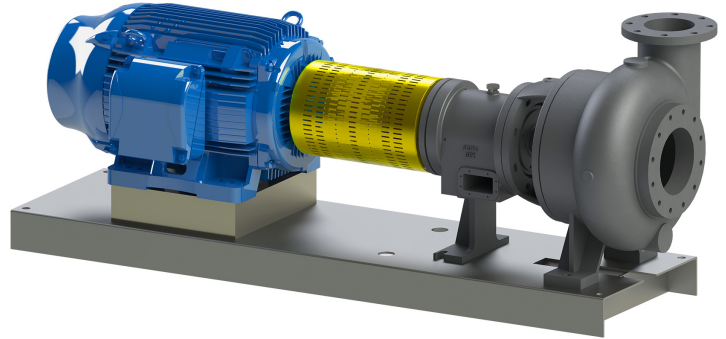

Model-Specific Options

- Space-saving close-coupled model reduces install footprint

Dimensions*

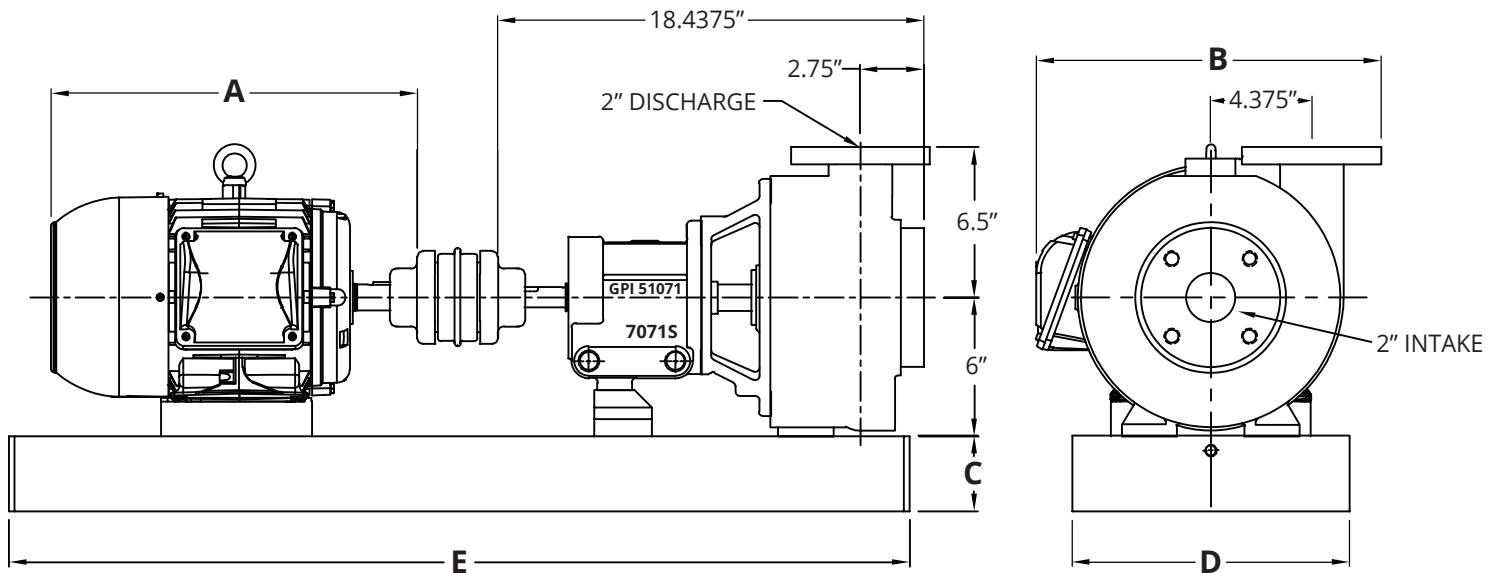

HP	NEMA Motor Frame Size	Base	Motor Length (A)	Conduit Box to Shaft Width (B)	Base Height (C)	Base Width (D)	Base Length (E)	Weight (lbs)
1.5	143T	67220-1S	13.346"	13.38"	3.00"	10.00"	35.00"	315
2	145T	67220-1S	13.346"	13.38"	3.00"	10.00"	35.00"	315
3	182T	67220-2S	15.86"	15.00"	3.25"	12.00"	39.00"	360
5	184T	67220-2S	15.86"	15.00"	3.25"	12.00"	39.00"	365
7.5	213T	67220-2S	19.53"	16.00"	3.25"	12.00"	39.00"	435
10	215T	67220-2S	19.53"	16.00"	3.25"	12.00"	39.00"	440

*For reference only; not for construction. Contact Gusher Engineering for certified drawings.

Performance Curve

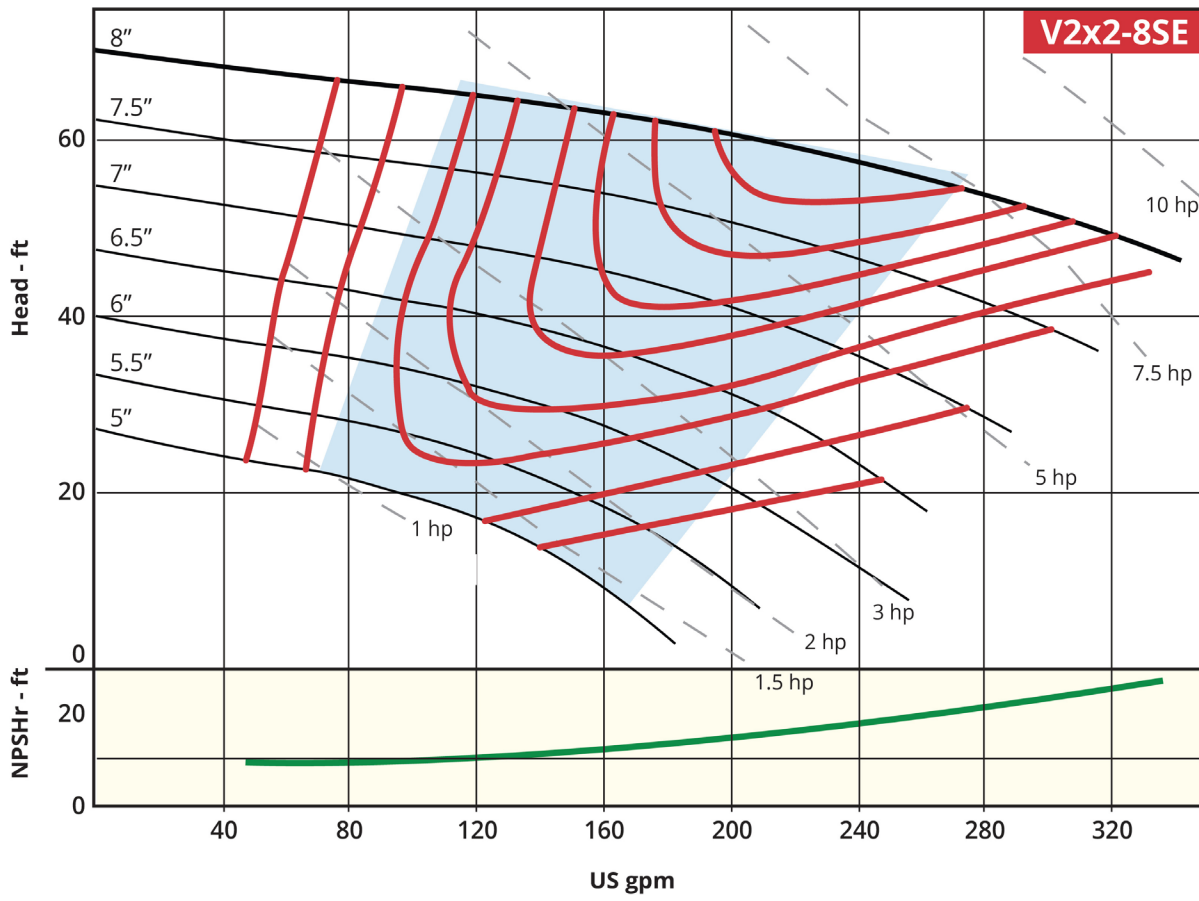

HORIZONTAL MODELS

Recommended Operating Range

V2x2-10SE

Key Specifications

- Flow:** Up to 360 gpm (1750 RPM)
- Head:** Up to 110' TDH (1750 RPM)
- Liquid Temp:** Max 180° F
- Power Options:** 3 hp, 5 hp, 7.5 hp, 10 hp and 15 hp
- Power Frame:** 7071M
- Motor Type:** TEFC, T Frame
- Max Solid Size:** 2"
- Intake:** 2"
- Discharge:** 2"

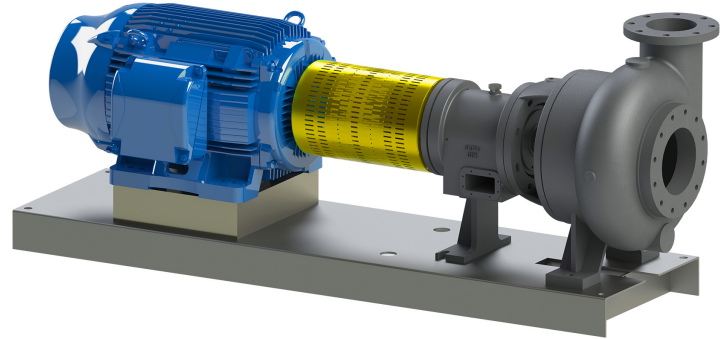

Model-Specific Options

- Space-saving close-coupled model reduces install footprint

Dimensions*

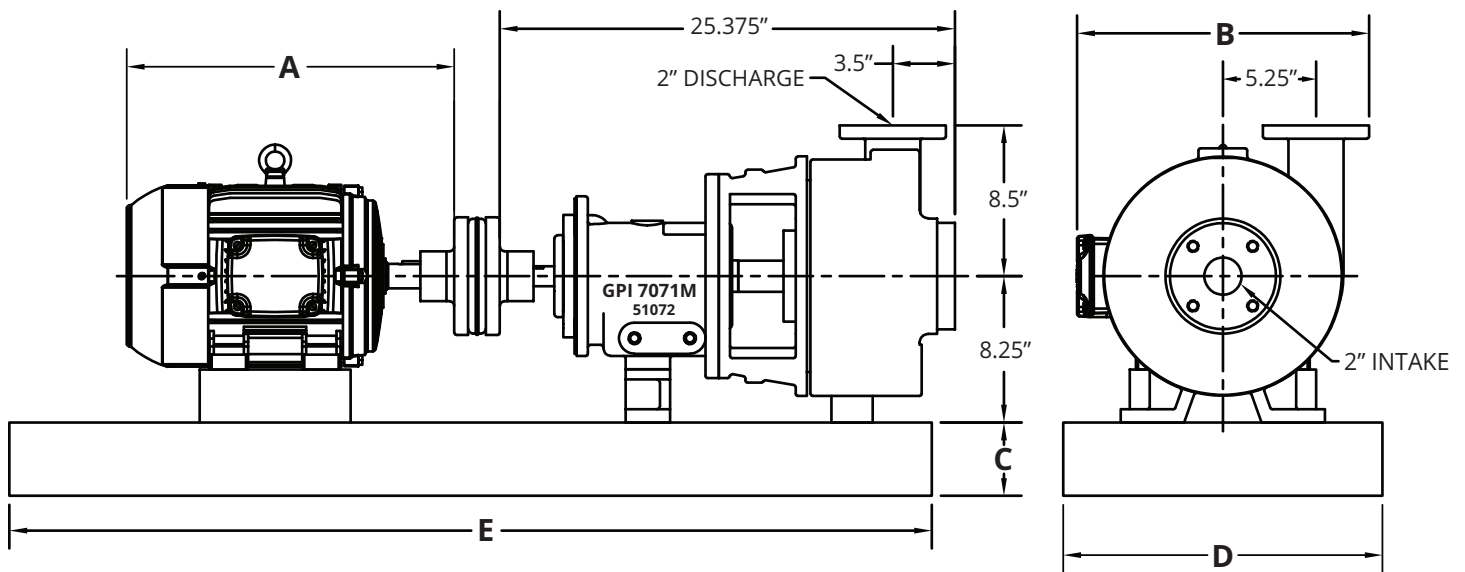

HP	NEMA Motor Frame Size	Base	Motor Length (A)	Conduit Box to Shaft Width (B)	Base Height (C)	Base Width (D)	Base Length (E)	Weight (lbs)
3	182T	67220-1M	15.86"	7.60"	3.75"	12.00"	45.00"	550
5	184T	67220-1M	15.86"	7.60"	3.75"	12.00"	45.00"	550
7.5	213T	67220-1M	19.53"	8.60"	3.75"	12.00"	45.00"	590
10	215T	67220-1M	19.53"	8.60"	3.75"	12.00"	45.00"	595
15	254T	67220-2M	25.00"	10.50"	4.13"	15.00"	52.00"	830

*For reference only; not for construction. Contact Gusher Engineering for certified drawings.

Performance Curve

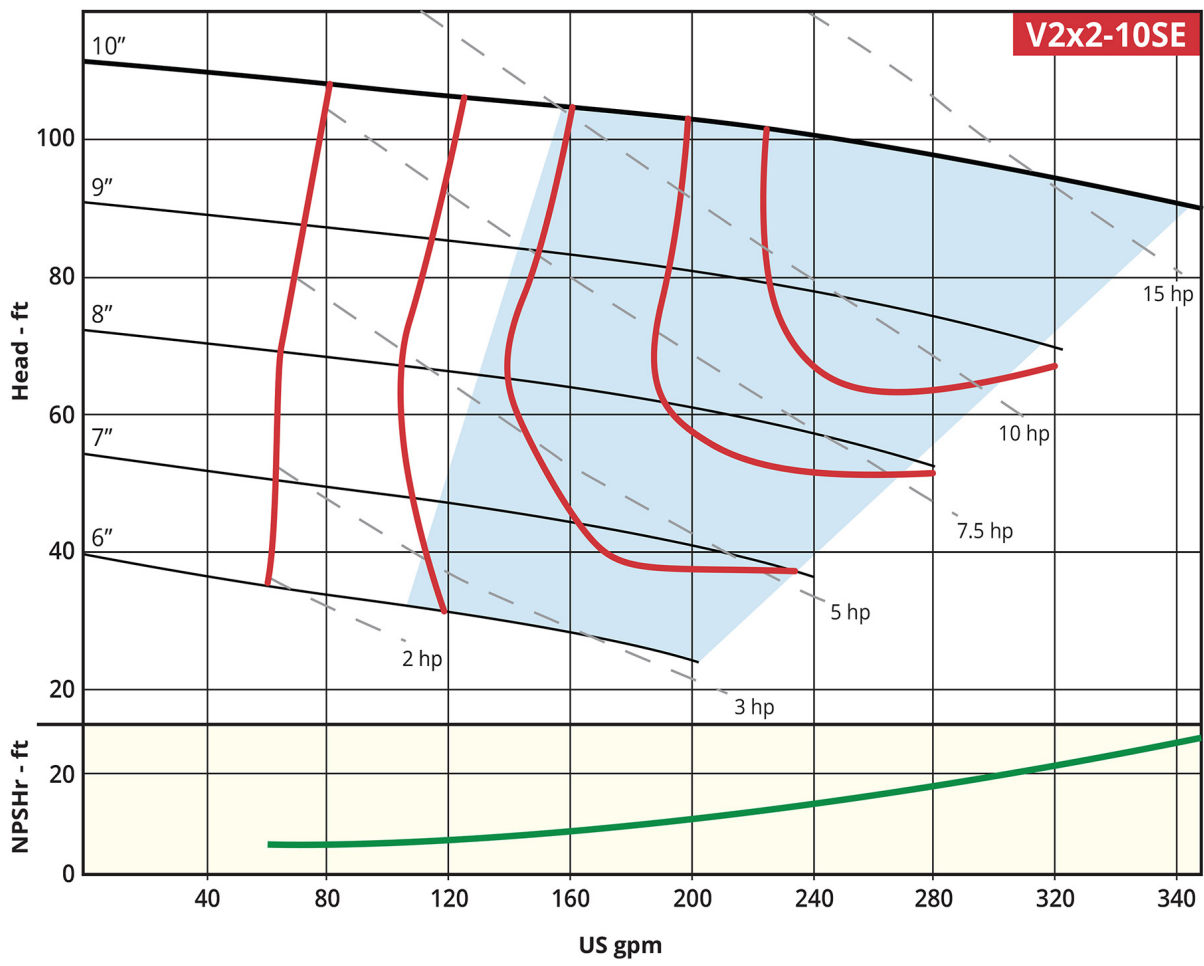

HORIZONTAL MODELS

Recommended Operating Range

V2x3-13SE

Key Specifications

- Flow:** Up to 620 gpm (1750 RPM)
- Head:** Up to 200' TDH (1750 RPM)
- Liquid Temp:** Max 180° F
- Power Options:** 15 hp, 20 hp, 25 hp, 30 hp, 40 hp and 50 hp
- Power Frame:** 7071M
- Motor Type:** TEFC, T Frame
- Max Solid Size:** 2"
- Intake:** 3"
- Discharge:** 2"

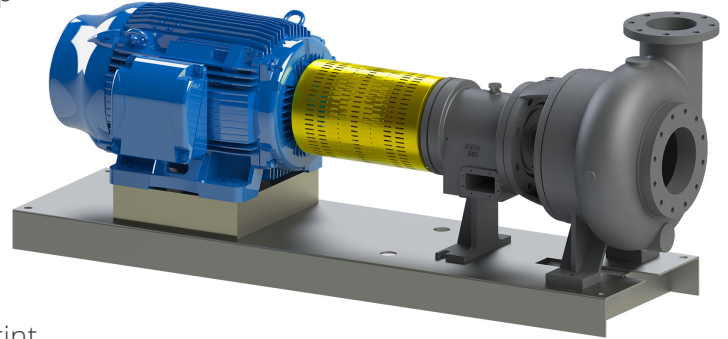

Model-Specific Options

- Space-saving close-coupled model reduces install footprint

Dimensions*

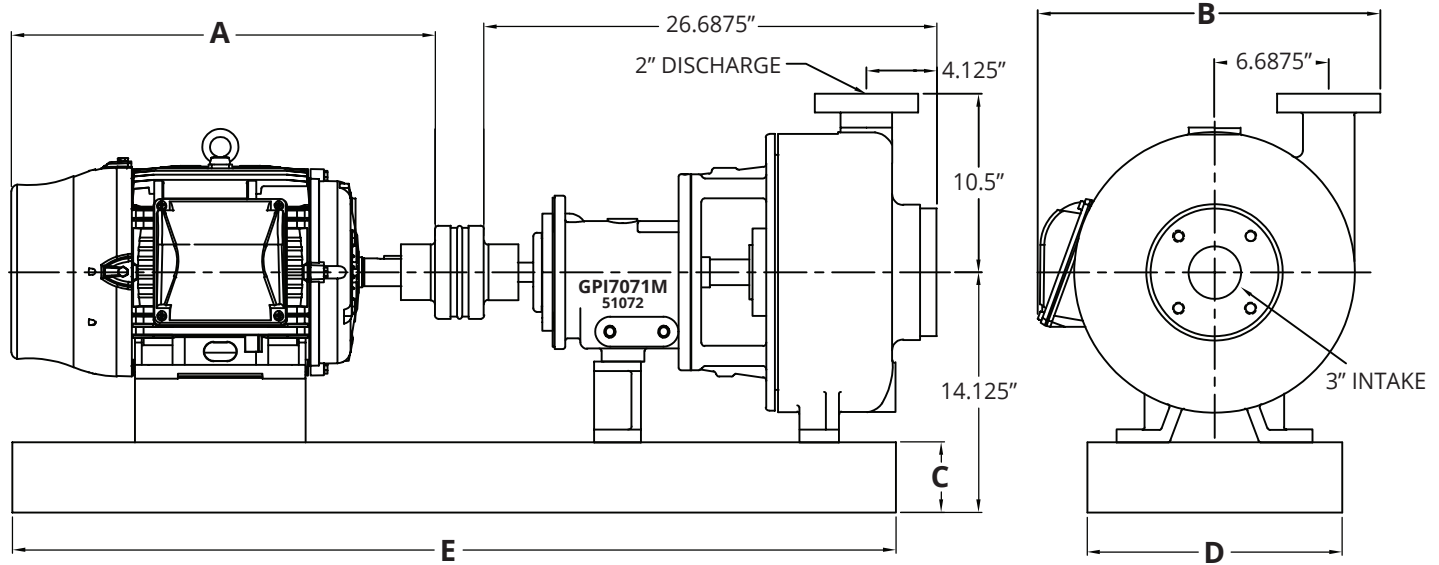

HP	NEMA Motor Frame Size	Base	Motor Length (A)	Conduit Box to Shaft Width (B)	Base Height (C)	Base Width (D)	Base Length (E)	Weight (lbs)
15	254T	67220-2M	25.00"	20.25"	4.13"	15"	52"	830
20	256T	67220-2M	25.00"	20.25"	4.13"	15"	52"	850
25	284T	67220-2M	28.00"	20.75"	4.13"	15"	52"	920
30	286T	67220-2M	28.00"	20.75"	4.13"	15"	52"	970
40	324T	67220-3M1	31.13"	22.38"	4.75"	18"	58"	1,120
50	Contact Factory							

*For reference only; not for construction. Contact Gusher Engineering for certified drawings.

Performance Curve

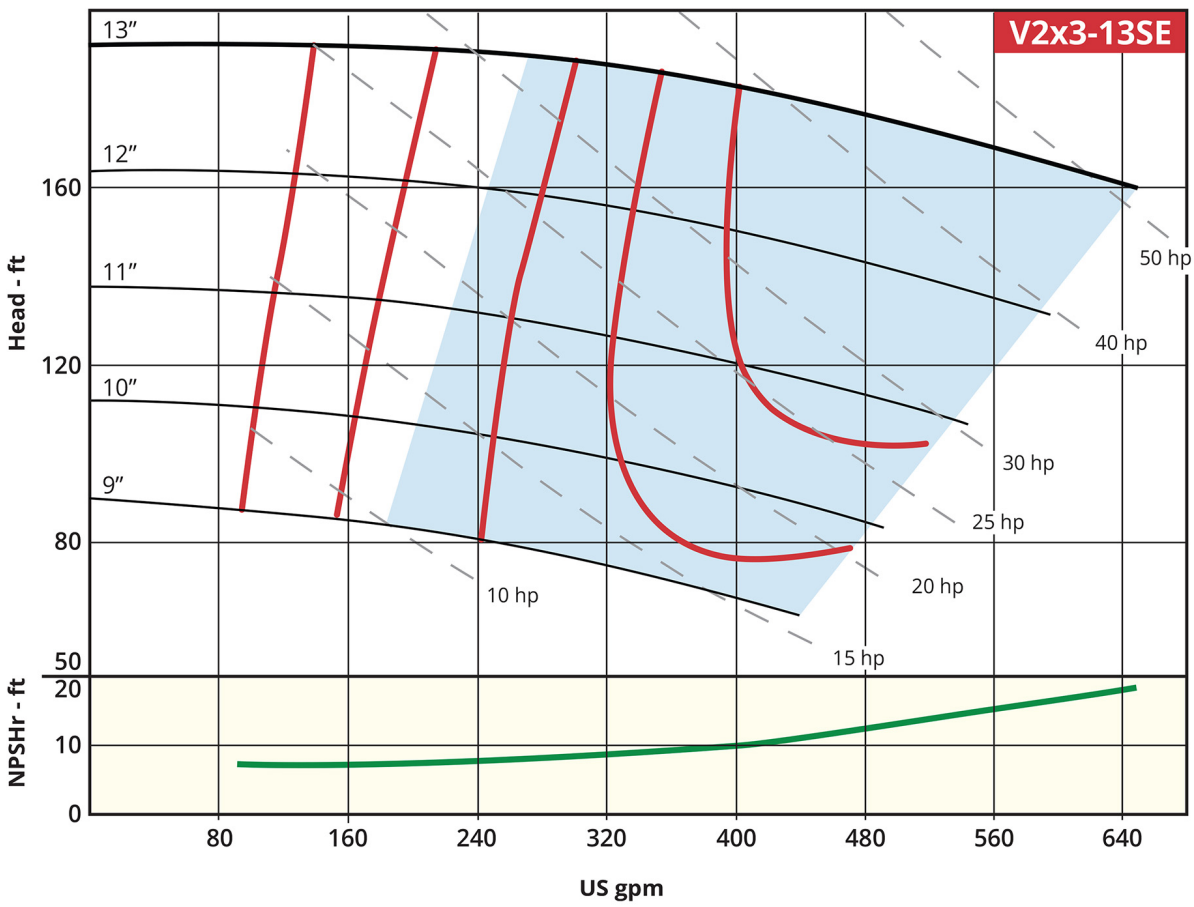

HORIZONTAL MODELS

Recommended Operating Range

V3x3-10SE

Key Specifications

Flow: Up to 760 gpm (1750 RPM)

Head: Up to 110' TDH (1750 RPM)

Liquid Temp: Max 180° F

Power Options: 7.5 hp, 10 hp, 15 hp, 20 hp, 25 hp, 30 hp and 40 hp

Power Frame: 7071M

Motor Type: TEFC, T Frame

Max Solid Size: 3"

Intake: 3"

Discharge: 3"

Model-Specific Options

- Space-saving close-coupled model reduces install footprint

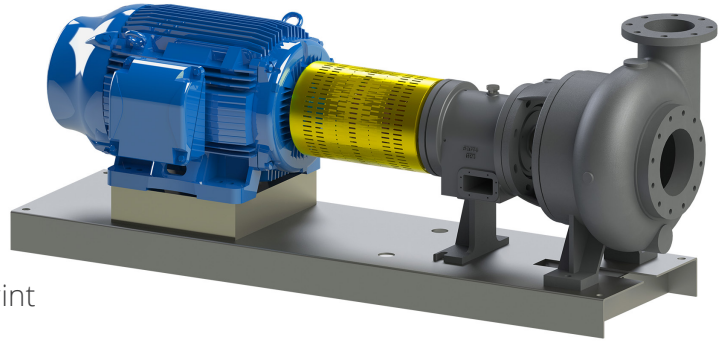

Dimensions*

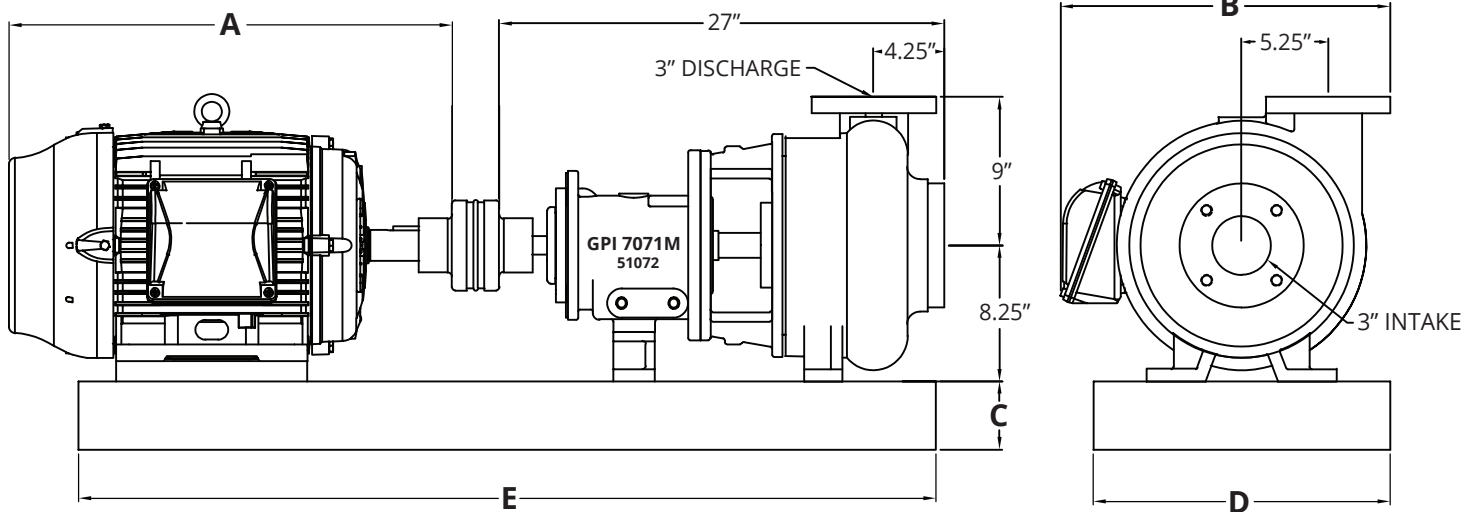

HP	NEMA Motor Frame Size	Base	Motor Length (A)	Conduit Box to Shaft Width (B)	Base Height (C)	Base Width (D)	Base Length (E)	Weight (lbs)
7.5	213T	67220-1M	19.53"	16.85"	3.75"	12.00"	45.00"	590
10	215T	67220-1M	19.53"	16.85"	3.75"	12.00"	45.00"	595
15	254T	67220-2M	25.00"	18.75"	4.13"	15.00"	52.00"	830
20	256T	67220-2M	25.00"	18.75"	4.13"	15.00"	52.00"	850
25	284T	67220-3M1	28.00"	20.00"	4.75"	18.00"	58.00"	900
30	286T	67220-3M1	28.00"	20.00"	4.75"	18.00"	58.00"	950
40	324T	67220-3M1	31.13"	21.63"	4.75"	18.00"	58.00"	1,100

*For reference only; not for construction. Contact Gusher Engineering for certified drawings.

Performance Curve

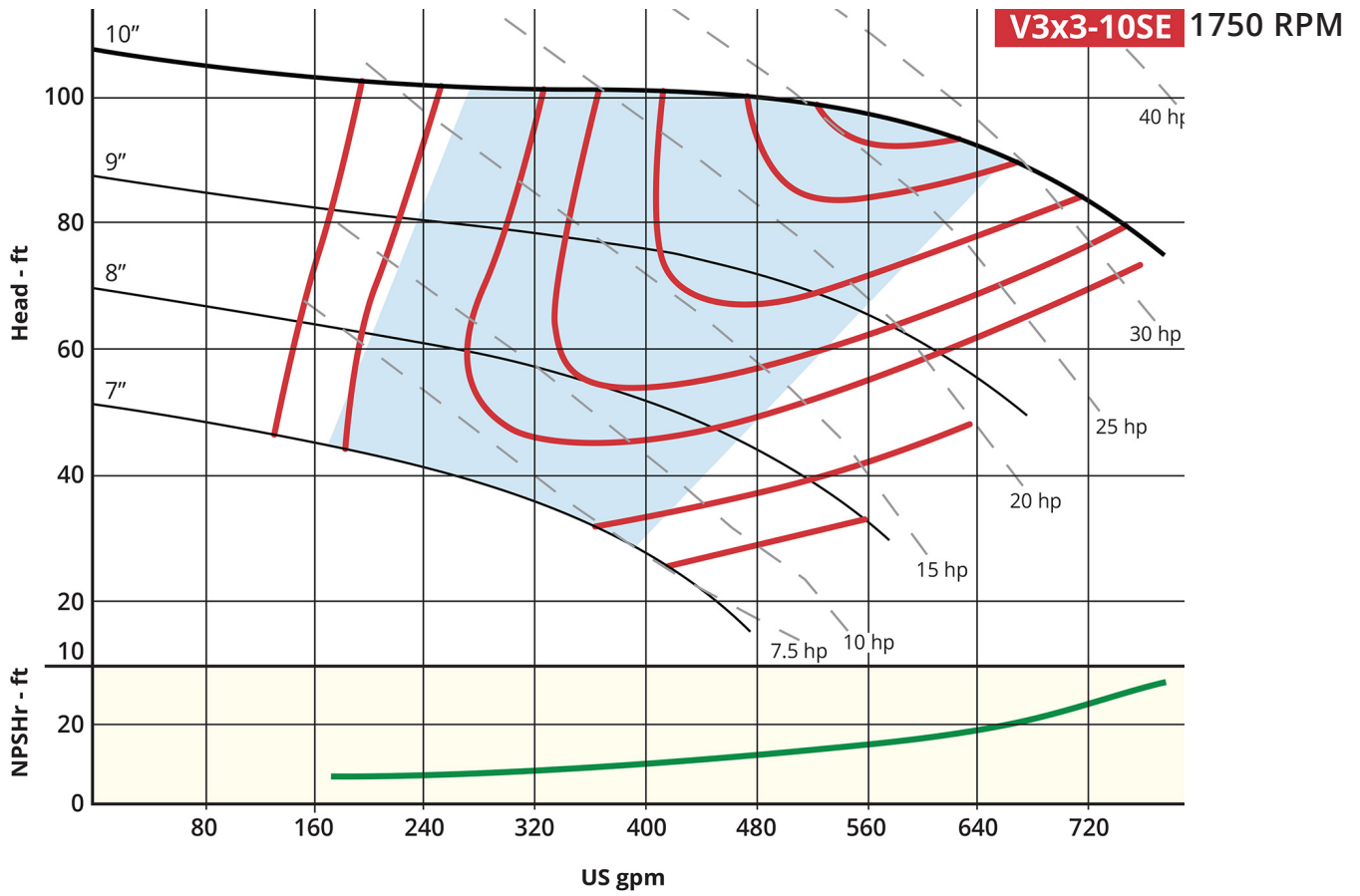

HORIZONTAL MODELS

Recommended Operating Range

V3x4-13SE

Key Specifications

- Flow:** Up to 210 gpm (1750 RPM)
- Head:** Up to 1,150' TDH (1750 RPM)
- Liquid Temp:** Max 180° F
- Power Options:** 30 hp, 40 hp, 50 hp, 60 hp, 75 hp and 100 hp
- Power Frame:** 7071M
- Motor Type:** TEFC, T Frame
- Max Solid Size:** 3"
- Intake:** 4"
- Discharge:** 3"

Model-Specific Options

- Space-saving close-coupled model reduces install footprint

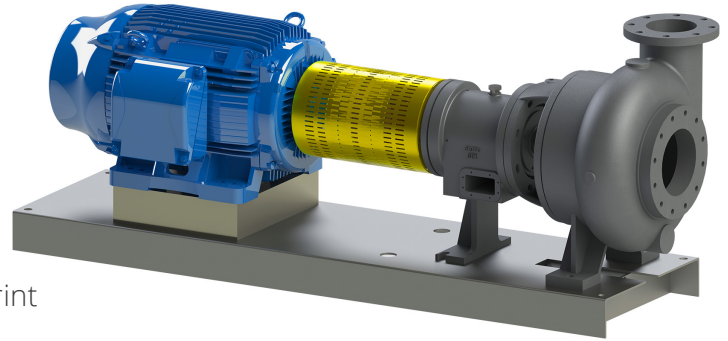

Dimensions*

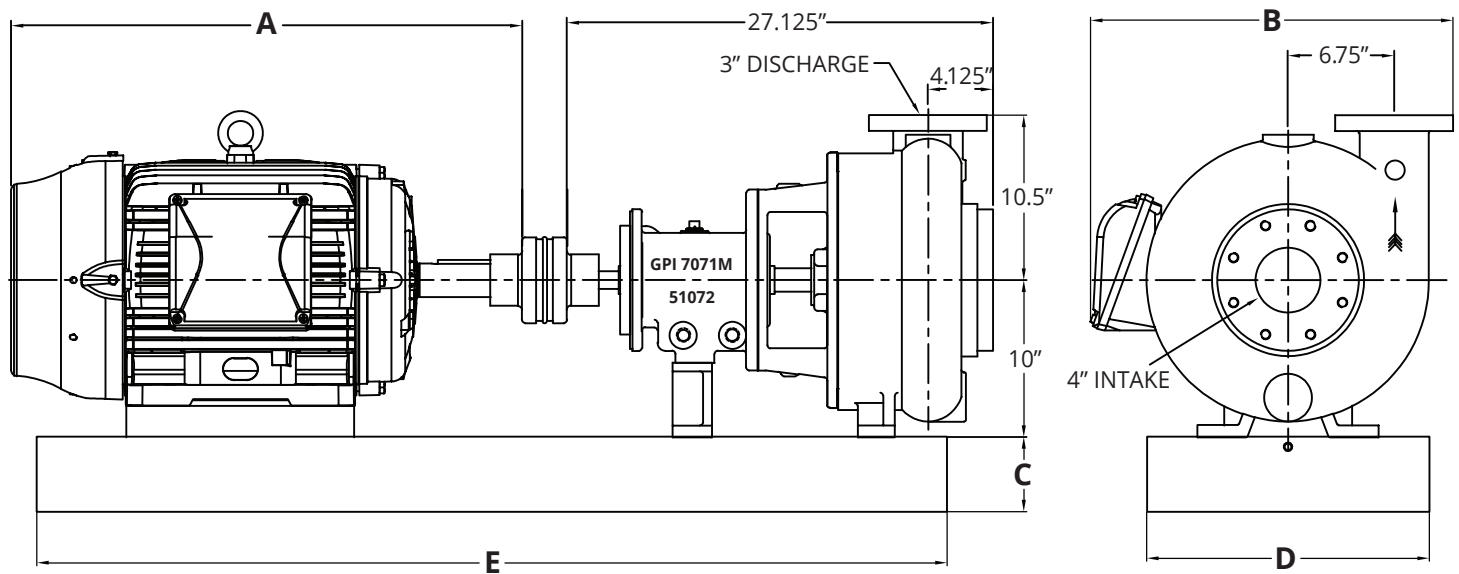

HP	NEMA Motor Frame Size	Base	Motor Length (A)	Conduit Box to Shaft Width (B)	Base Height (C)	Base Width (D)	Base Length (E)	Weight (lbs)
30	286T	67220-3M1	28.00"	21.63"	4.75"	18.00"	58.00"	1,038
40	324T	67220-3M1	31.13"	23.00"	4.75"	18.00"	58.00"	1,160
50	326T	67220-3M1	31.13"	23.00"	4.75"	18.00"	58.00"	1,200
60	364T	67220-3M2	34.50"	25.50"	5.75"	18.00"	58.00"	1,475
75	365T	67220-3M2	34.50"	26.50"	5.75"	18.00"	58.00"	1,538
100	Contact Factory							

*For reference only; not for construction. Contact Gusher Engineering for certified drawings.

Performance Curve

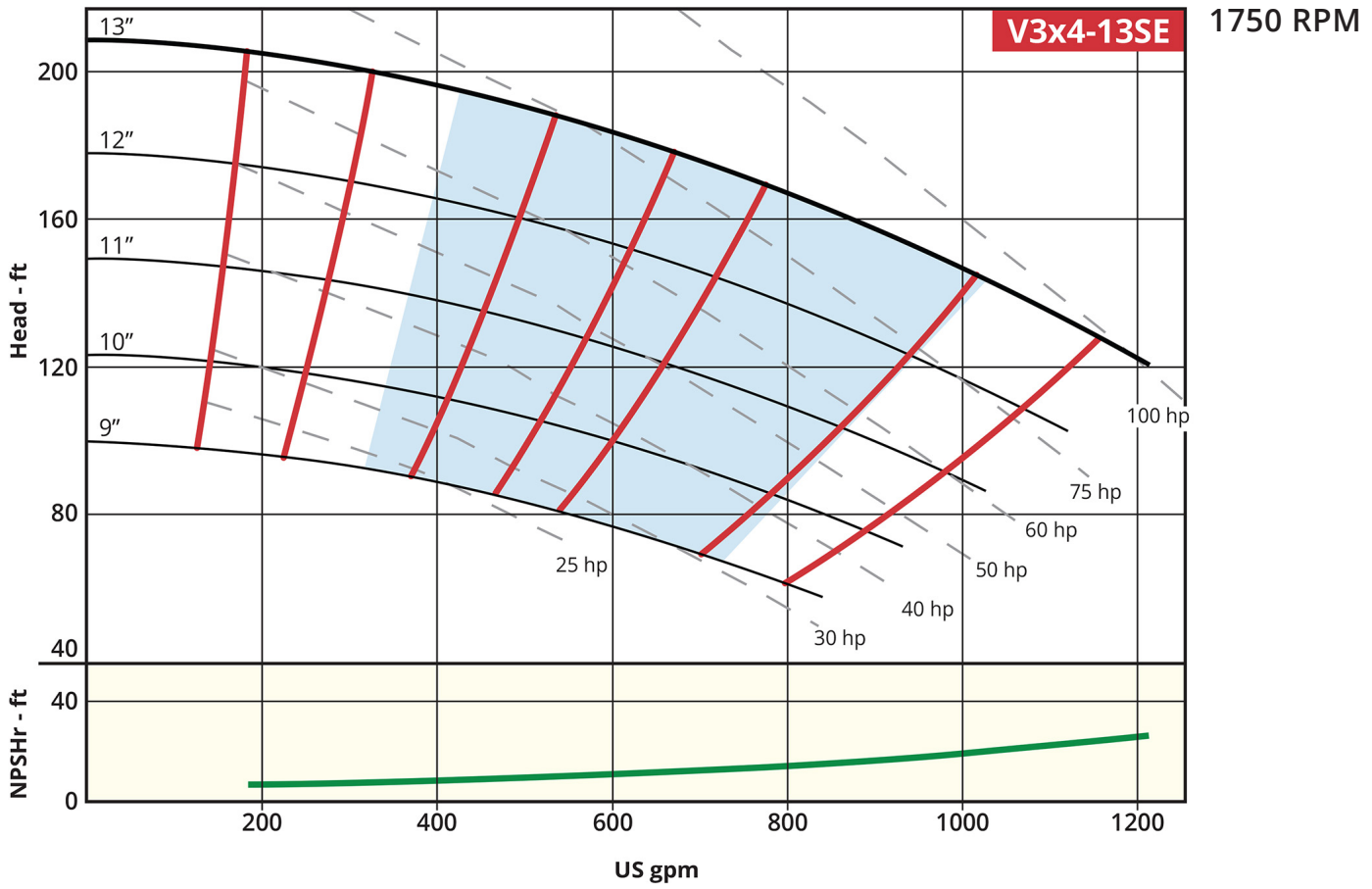

HORIZONTAL MODELS

Recommended Operating Range

V4x6-13SE

Key Specifications

- Flow:** Up to 180 gpm (1750 RPM)
- Head:** Up to 1,500' TDH (1750 RPM)
- Liquid Temp:** Max 180° F
- Power Options:** 40 hp, 50 hp, 60 hp, 75 hp and 100 hp
- Power Frame:** 7071M
- Motor Type:** TEFC, T Frame
- Max Solid Size:** 4"
- Intake:** 6"
- Discharge:** 4"

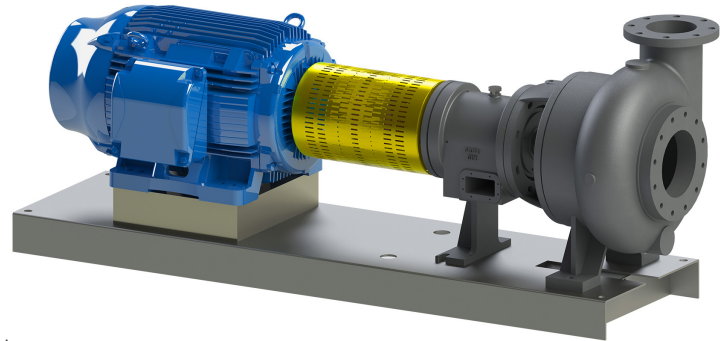

Model-Specific Options

- Space-saving close-coupled model reduces install footprint

Dimensions*

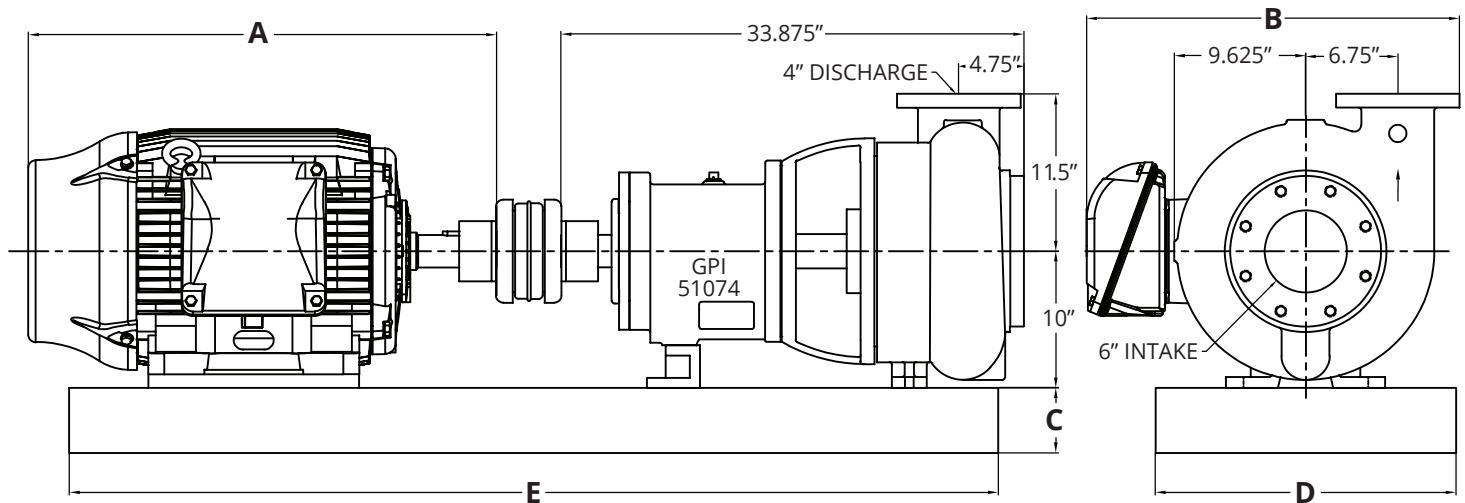

HP	NEMA Motor Frame Size	Base	Motor Length (A)	Conduit Box to Shaft Width (B)	Base Height (C)	Base Length (D)	Base Width (E)	Weight (lbs)
40	324T	67220-2L	31.13"	23.85"	4.75"	22.00"	68.00"	1,415
50	326T	67220-2L	31.13"	23.85"	4.75"	22.00"	68.00"	1,450
60	364T	67220-2L	34.50"	27.25"	4.75"	22.00"	68.00"	1,715
75	365T	67220-2L	34.50"	27.25"	4.75"	22.00"	68.00"	1,780
100	405T	67220-3L	39.73"	27.25"	4.75"	22.00"	80.00"	2,050

*For reference only; not for construction. Contact Gusher Engineering for certified drawings.

Performance Curve

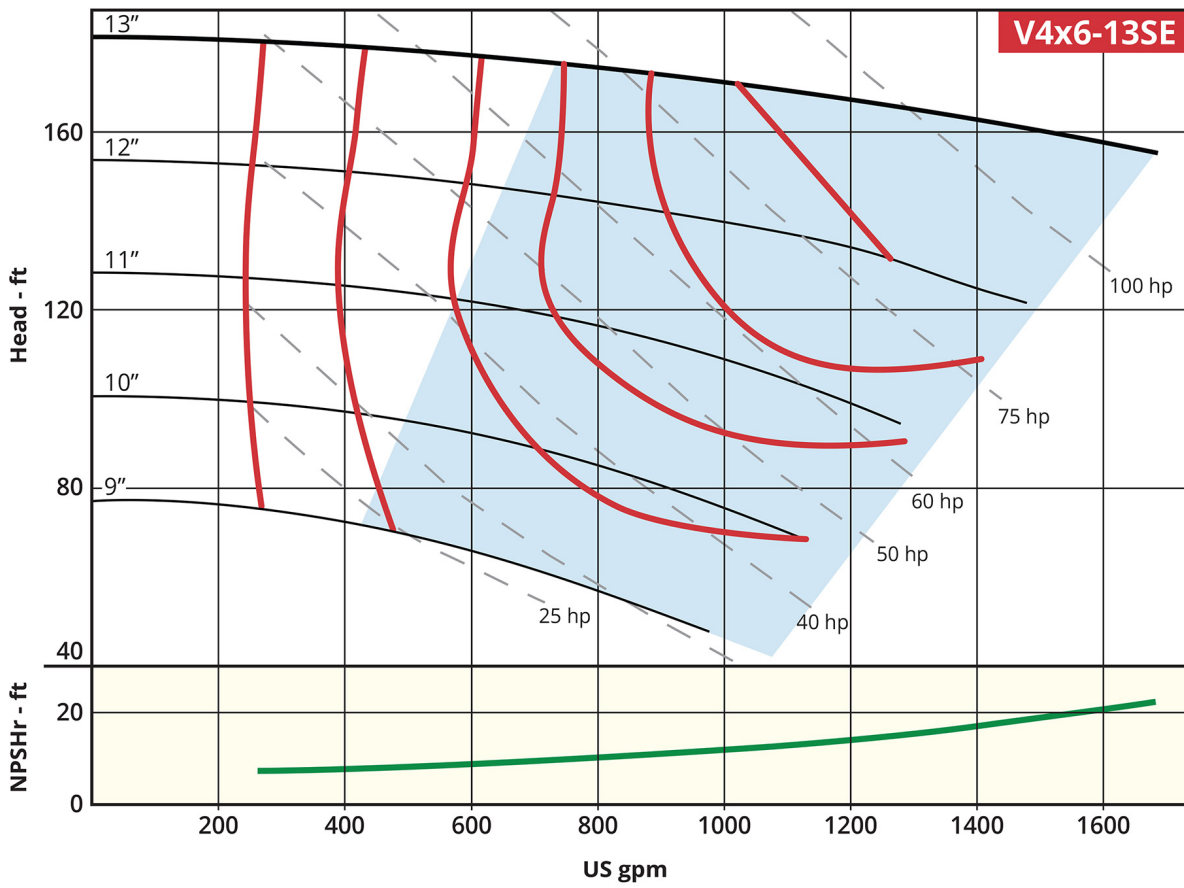

HORIZONTAL MODELS

Recommended Operating Range

V6x8-15SE

Key Specifications

Flow: Up to 200 gpm (1750 RPM)

Head: Up to 2,400' TDH (1750 RPM)

Liquid Temp: Max 180° F

Power Options: 60 hp, 75 hp, 100 hp, 125 hp, 150 hp and 200 hp

Power Frame: 7071L

Motor Type: TEFC, T Frame

Max Solid Size: 6"

Intake: 8"

Discharge: 6"

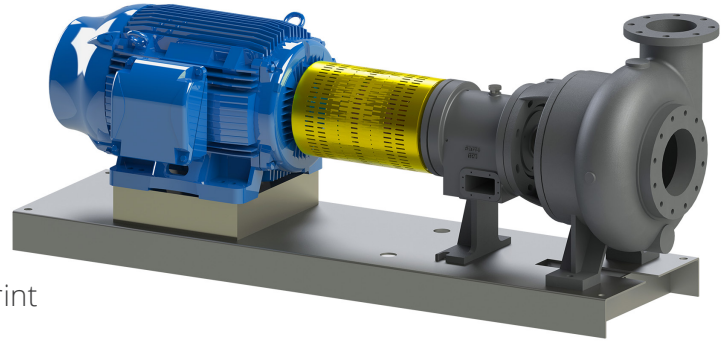

Model-Specific Options

- Space-saving close-coupled model reduces install footprint

Dimensions*

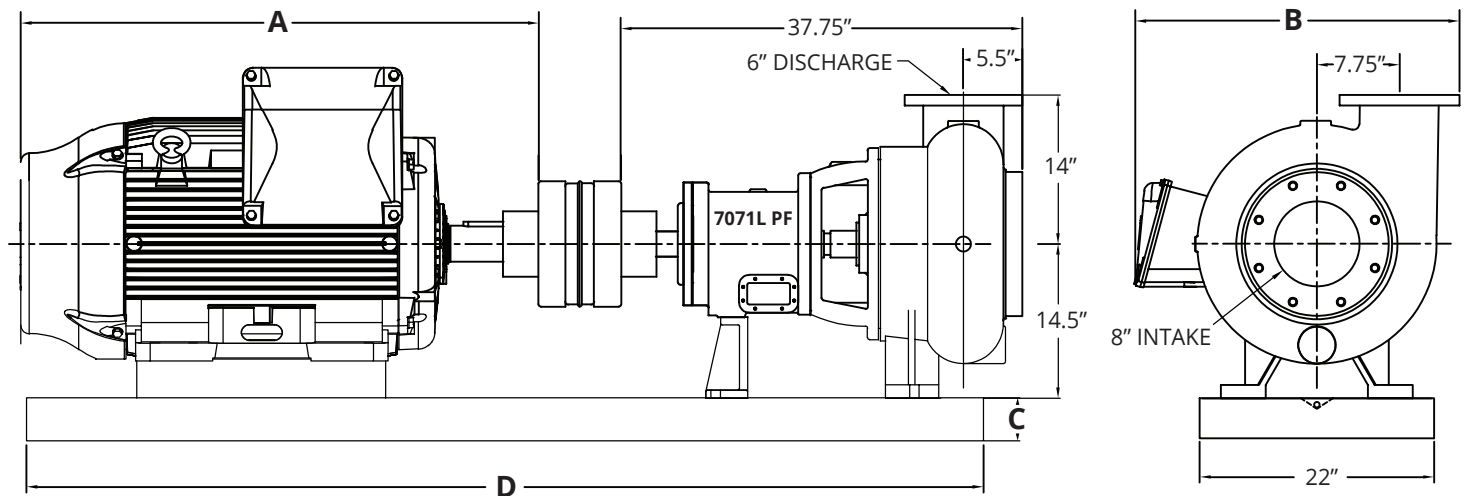

HP	NEMA Motor Frame Size	Base	Motor Length (A)	Conduit Box to Shaft Width (B)	Base Height (C)	Base Length (D)	Weight (lbs)
60	364T	67220-2L	34.50"	29.38"	4.75"	68.00"	2,000
75	365T	67220-2L	34.50"	29.38"	4.75"	68.00"	2,060
100	405T	67220-3L	39.75"	29.50"	4.75"	80.00"	2,330
125	444T	67220-3L	45.25"	32.00"	4.75"	80.00"	2,700
150	445T	67220-3L	45.25"	32.00"	4.75"	80.00"	2,950
200	Contact Factory						

*For reference only; not for construction. Contact Gusher Engineering for certified drawings.

Performance Curve

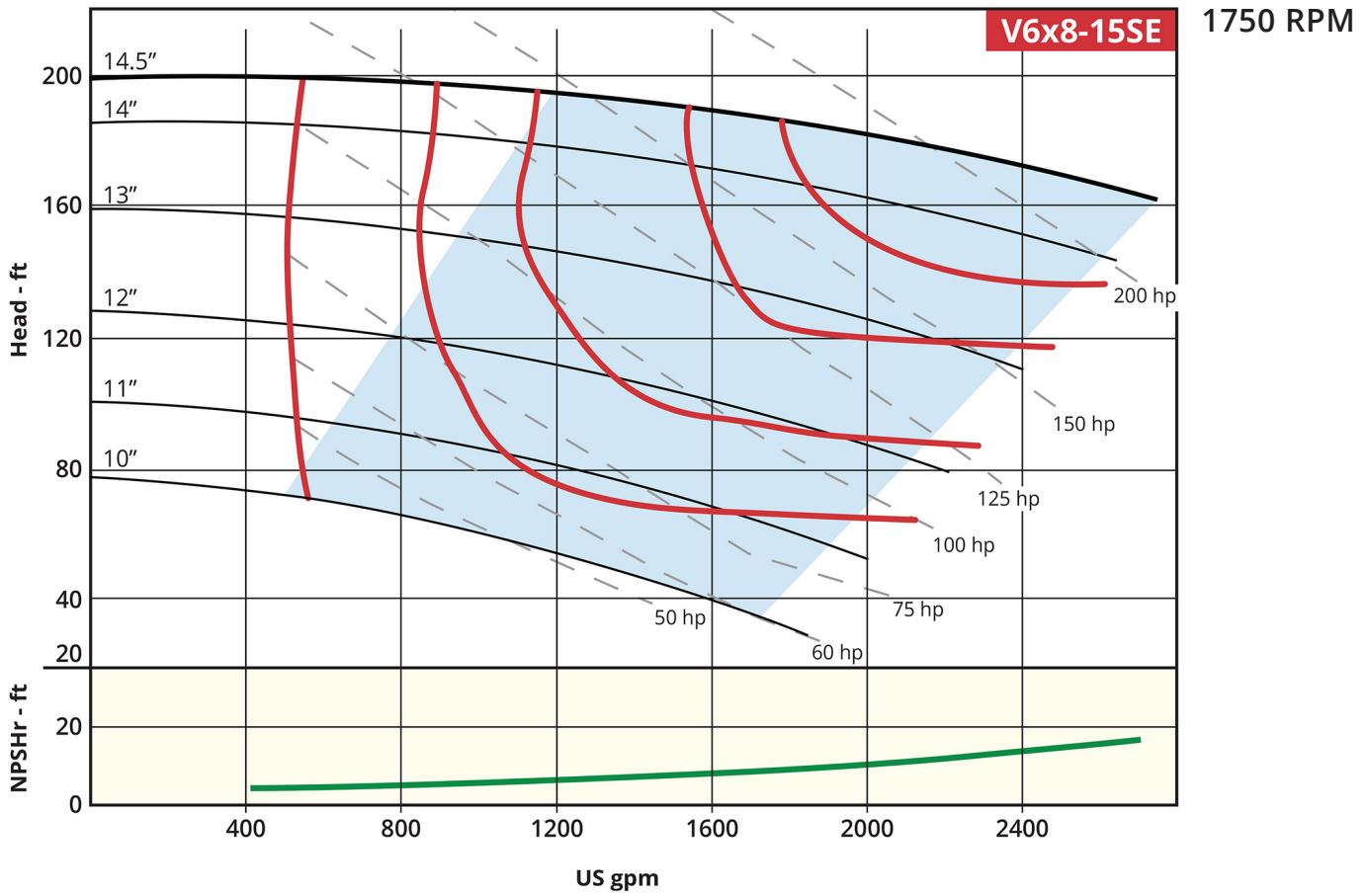

HORIZONTAL MODELS

Recommended Operating Range

V11019-AHSE

Key Specifications for 1750 & 3450 RPM Models

Flow: Up to 110 gpm (1750 RPM) | Up to 210 gpm (3450 RPM)

Head: Up to 32' TDH (1750 RPM) | Up to 124' TDH (3450 RPM)

Liquid Temp: Max 180° F

Power Options: 1 hp, 1.5 hp, 2 hp, 3 hp, 5 hp, 7.5 hp and 10 hp

Motor Type: Standard JP Motor

Max Solid Size: .5"

Intake: 2"

Discharge: 1.5"

Model-Specific Feature

- Durable one-piece shaft eliminates risk of coupling misalignment

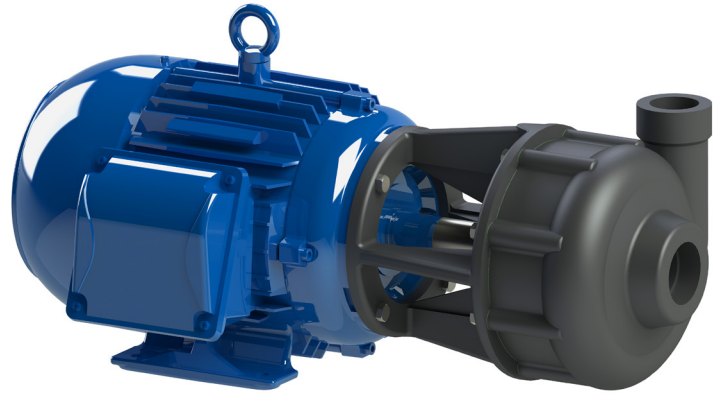

Dimensions*

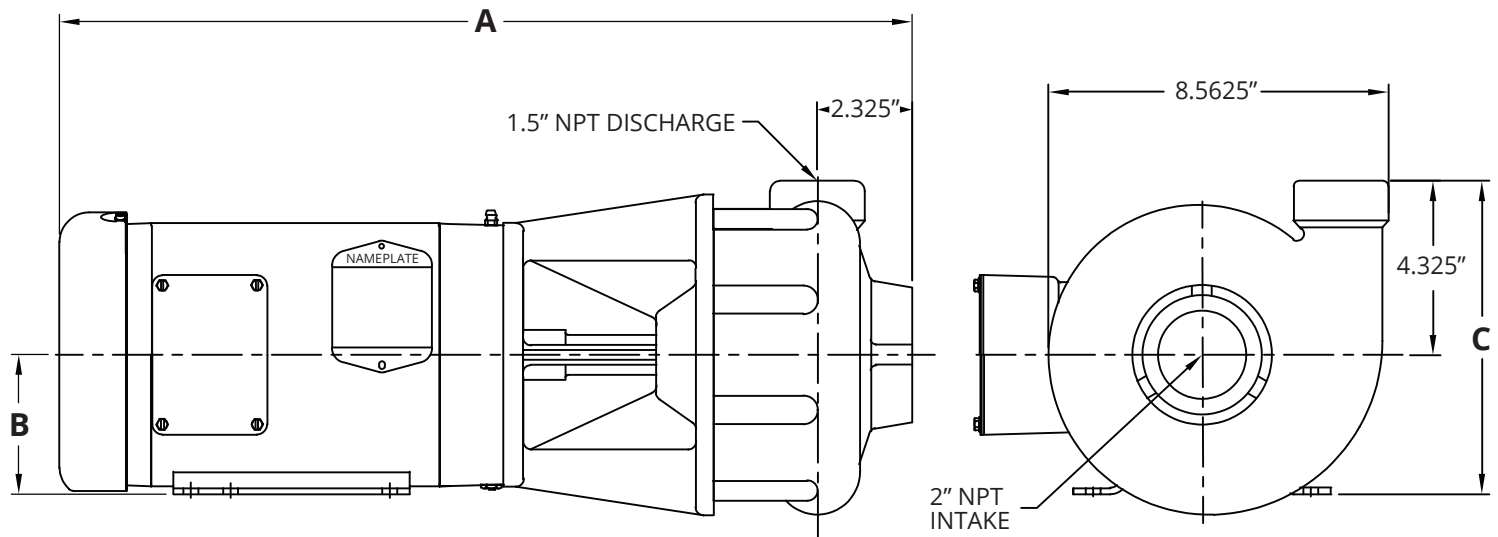

1750 RPM

HP	Total Length (A)	Motor Center to Foot (B)	Total Height (C)	Weight (lbs)
1	22.00"	3.50"	8"	80
1.5	22.50"	3.50"	8"	90
2	22.50"	3.50"	8"	95
3	22.00"	4.50"	9"	120

3450 RPM

HP	Total Length (A)	Motor Center to Foot (B)	Total Height (C)	Weight (lbs)
1.5	22.50"	3.50"	8"	90
2	22.50"	3.50"	8"	95
3	22.00"	4.50"	9"	120
5	23.25"	4.50"	9"	140
7.5	26.25"	4.50"	9"	150
10	27.00"	5.25"	9.75"	200

*Motor dimensions may vary slightly by motor manufacturer

Performance Curve

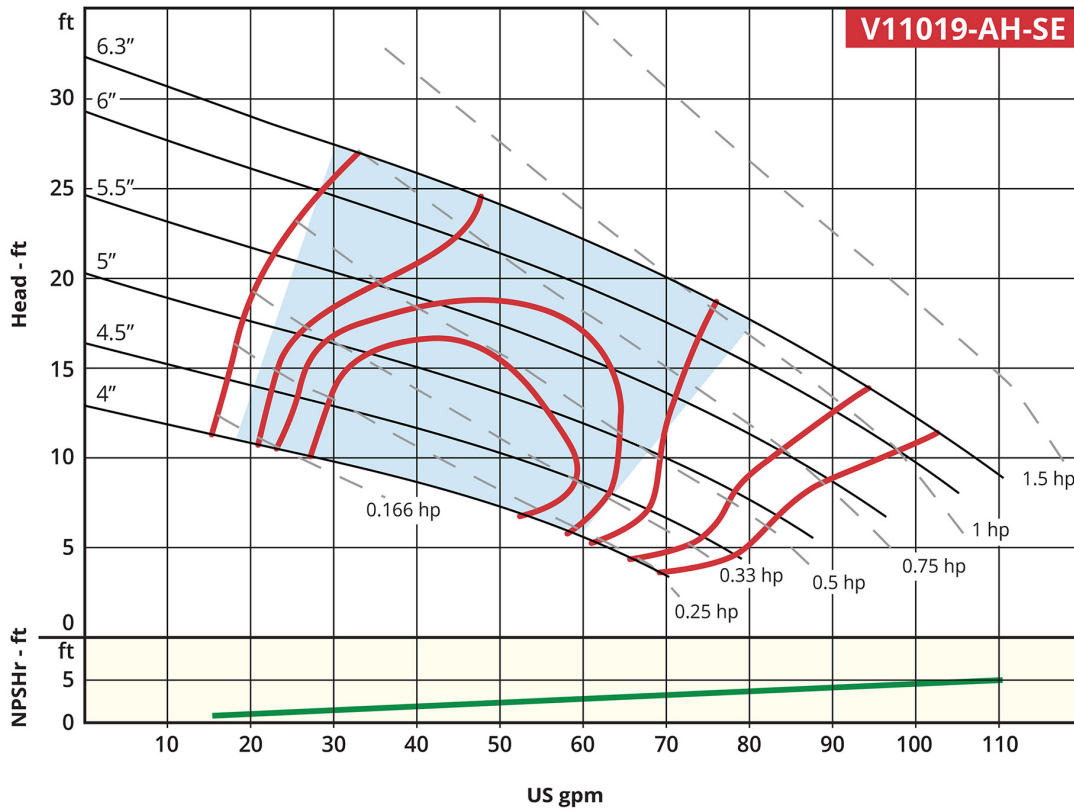

V11019A-SE are available in 1 hp, 1.5 hp, 2 hp and 3 hp models. Other hp shown for reference only.

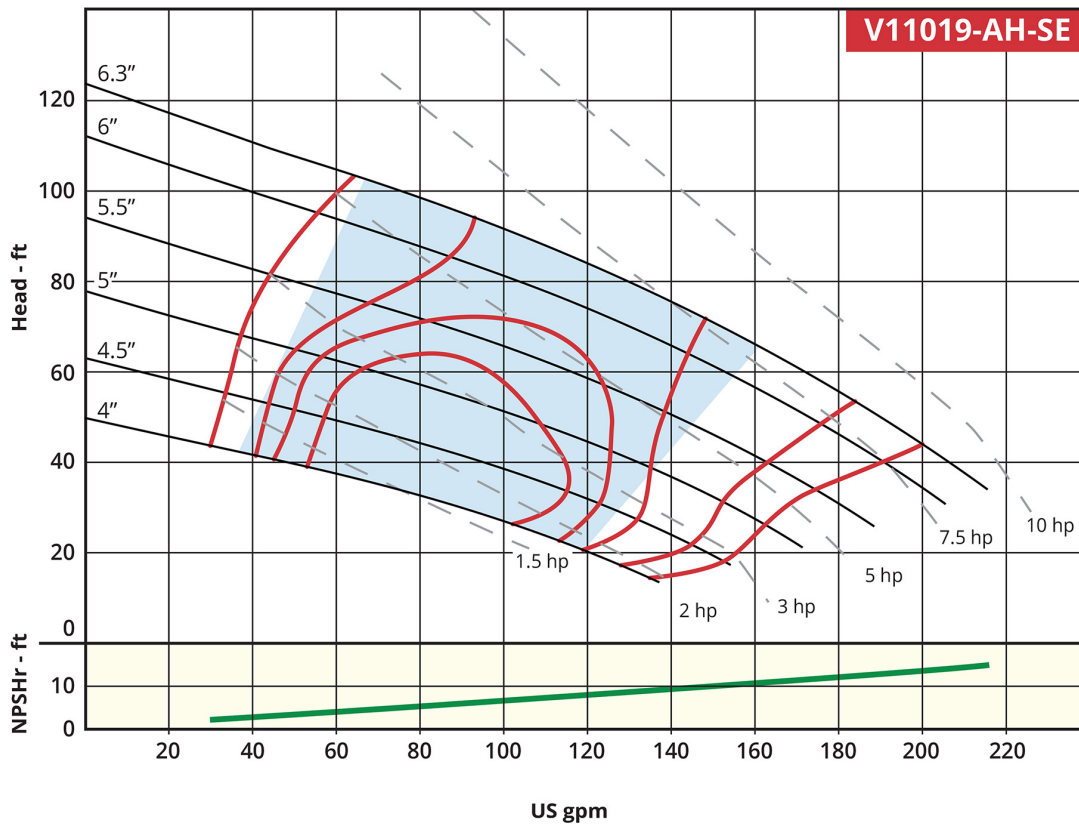

Recommended Operating Range

HORIZONTAL MODELS

Ruthman Companies: A family-owned business supplying pumps for over 100 years

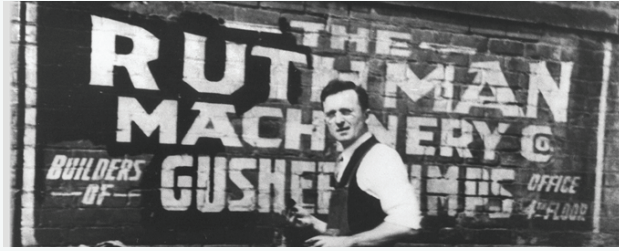

Ruthman Companies was co-founded in 1912 by brothers Alois and Edward Ruthman as the “Ruthman Machinery Company.” Based in Cincinnati, the company serviced the steamboats that traveled the Ohio River. In 1924, Alois conceived the first seal-less centrifugal pump, coining the term ‘coolant pump.’ The brothers named this new pump “Gusher,” giving birth to what is now Ruthman Companies’ flagship brand, Gusher Pumps.

Alois’ son Thomas R. Ruthman joined the family business in 1949, growing the business globally through organic growth and the acquisition of complementary technologies. In the early 1990’s, Alois’ grandson, Thomas G. Ruthman, became the third generation of Ruthmans in the pump business. Over the years, Ruthman Companies has expanded its product line from the original centrifugal coolant pumps to include valves, vertical turbine pumps, positive displacement pumps, gear pumps, and other specialized pump equipment, while upholding its reputation as a leader in the custom engineering of pumps for the most challenging applications.

GUSHER PUMPS LOCATIONS

Williamstown Headquarters

115 Industrial Road
Williamstown, KY 41097
Phone: 859.824.3011
Email: Info@Gusher.com
www.Gusher.com

Dry Ridge Manufacturing

22 Ruthman Drive
Dry Ridge, KY 41035
Phone: 859.824.5001
Email: Info@Gusher.com

Dry Ridge Training Facility

3565 Dixie Highway
Dry Ridge, KY 41035
Phone: 859.824.5001
Email: Info@Gusher.com

New Castle Sales & Service

403 North Ninth Street
New Castle, IN 47362
Phone: 765.529.5624
Email: GusherNC@Gusher.com

Gusher Pumps, Shanghai

655 Caosheng Road
Jiading District
Shanghai, China 201808
Phone: +86 (021) 55151993
Email: Flomo@Gusher.com

RUTHMAN COMPANIES MANUFACTURING DIVISIONS

BSM Pump Corp.

260 Narragansett Park Drive
East Providence, RI 02916
Phone: 401.471.6350
Email: Sales@BSMPump.com
www.BSMPump.com

Fulflo Hydraulic Valves

459 East Fancy Street
Blanchester, OH 45107
Phone: 937.783.2411
Email: Info@Fulflo.com
www.Fulflo.com

Nagle Pumps

1249 Center Avenue
Chicago Heights, IL 60411
Phone: 708.754.2940
www.NaglePumps.com

Process Systems Inc. Headquarters

23601 Pinewood Street
Warren, MI 48091
Phone: 586.757.5711
Email: Sales@PSI4Pumps.com
www.PSI4Pumps.com

Process Systems Inc. Midwest Service

485 N. State Route 341 South
Mellott, IN 47958
Phone: 765.295.2206
Email: Sales@PSI4Pumps.com
www.PSI4Pumps.com

RAE Pumps

1212 Steng Street
Cincinnati, OH 45223
Phone: 513.779.3034
Email: Info@RAEPumps.com
www.RAEPumps.com

Ruthman Pumps & Service

1212 Steng Street
Cincinnati, OH 45223
Phone: 513.559.3546
www.RuthmanCompanies.com

Ruthmann Pumpen, LLC

Thomas-Edison-Str. 11
D-52499 Baesweiler
Germany
Phone: +49 (0) 2401 80489-0
Email: Info@RuthmannPumpen.de
www.RuthmannPumpen.de

RUTHMAN COMPANIES HEADQUARTERS

7236 Tylers Corner Drive
West Chester, OH 45069
Phone: 513.559.1901
www.RuthmanCompanies.com

