



A RUTHMAN COMPANY

7800 Series Vertical Pumps

11019-A
11019-ASE

3450 RPM

Gusher 7800 Series Vertical pumps provide years of trouble-free, low maintenance operation. Heavy duty bearings require only periodic lubrication. Renewable shaft sleeves and bushings extend pump life.

A sealless design is standard, eliminating the most common point of pump failure—the mechanical seal. Instead, the internal components are specifically engineered to minimize leakage. Maintenance and downtime are significantly reduced as there are no failed or worn seals to replace.

The enclosed column design option offers the flexibility of external tank ('dry-pit') mounting. The outer column of the sealless pump contains any incidental fluid overflow and returns it to the process or discharge point. This design conserves costly process fluids and keeps shop floors dry and hazard-free.



Key Specifications

Type: Centrifugal, End Suction

Flow: Up to 182 gpm

Head: Up to 170' TDH

Liquid Temp: Max 180° F

Max Solid Size: .375"

Motor Type: TCZ Frame

Intake: 2"

Discharge: 1.5"

Power: 1.5 hp, 2 hp, 3 hp, 5hp, 7.5 hp and 10 hp

Features

- Sealless design reduces maintenance by eliminating the need for failure-prone seals
- Renewable shaft sleeve protects shaft from wear
- Design flexibility to suit your exact install specifications with extended lengths, multiple mounting plates and adjustable brackets

Options

- Cast Iron or 316 Stainless construction
- Enclosed column
- Semi-enclosed impeller
- Multiple bushing materials
- Impeller variations: 316 Stainless Steel or recessed design
- Long coupled design
- Choice of 1 or 3 phase motor
- Extended shafts (6", 12", 18" or 24" standard; custom available, consult engineering)
- Adjustable mounting brackets
- Choice of plate shape/size (for above plate discharge, see 11019-AVD models)



Low Maintenance

- Long service life
- Renewable shaft sleeve and bushings

Custom Design

- Choice of materials
- Enclosed column option
- Semi-enclosed impeller option

Applications

- Cooling towers and chillers
- Wastewater
- Water purification
- Spray booths
- Parts washers
- Industrial washing machines



A RUTHMAN COMPANY

www.Gusher.com
Info@Gusher.com
859.824.5001

Performance Curves

3450 RPM

Recommended Operating Range

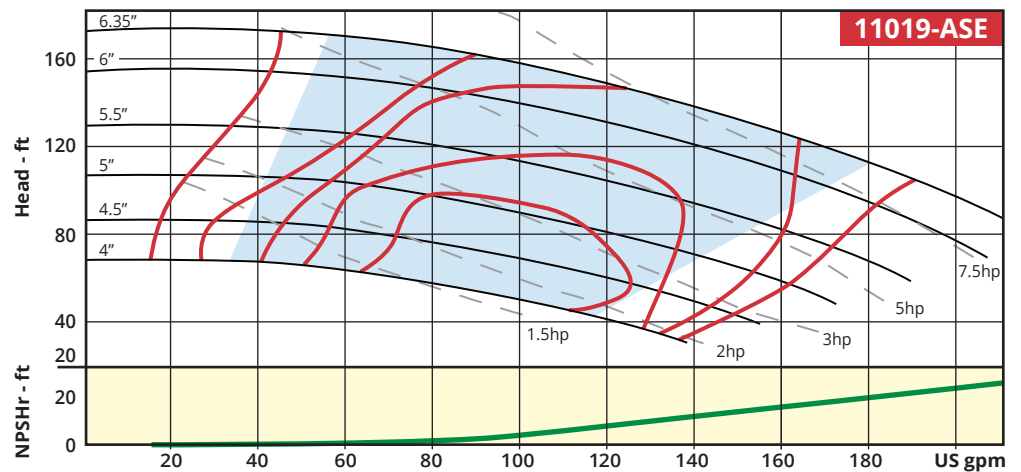
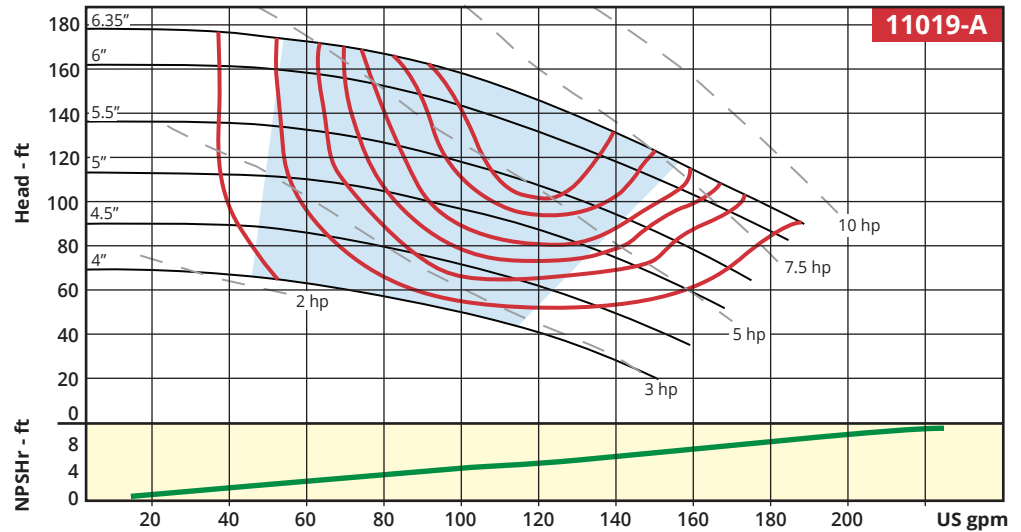

Dimensions*

| HP | Total Length (A) | Motor Bolt to Intake (B) | Weight (lbs) |
|-----|------------------|--------------------------|--------------|
| 1.5 | 27.125" | 14.375" | 90 |
| 2 | 27.875" | 14.375" | 95 |
| 3 | 27.875" | 14.375" | 120 |
| 5 | 29.25" | 14.375" | 140 |
| 7.5 | 30.50" | 14.375" | 150 |
| 10 | 31.00" | 14.375" | 200 |

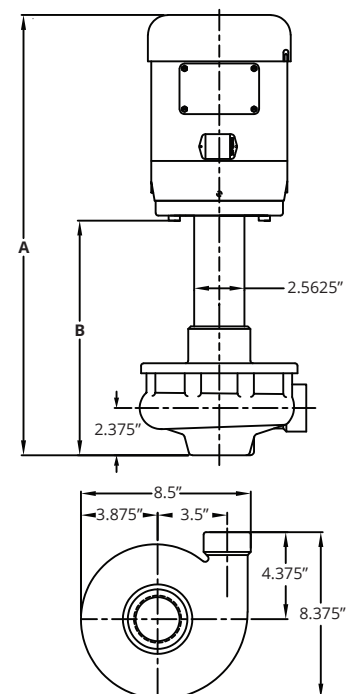

*For reference only; not for construction. Contact Gusher Engineering for certified drawings.

For extended lengths (6", 12", 18", 24", or custom), add extension length to Total Length