



## Low Maintenance

- Long service life
- Top pullout design option
- Renewable shaft sleeve and bushings

## Custom Design

- Choice of materials
- Choice of pump length
- Choice of bushing material

## Applications

- Agriculture
- Fibrous Waste
- Sludge
- Shavings
- Swarf
- Paper Pulp
- Wastewater



A RUTHMAN COMPANY

www.Gusher.com  
 Info@Gusher.com  
 859.824.5001

## Performance Curve

1750 RPM

### Recommended Operating Range

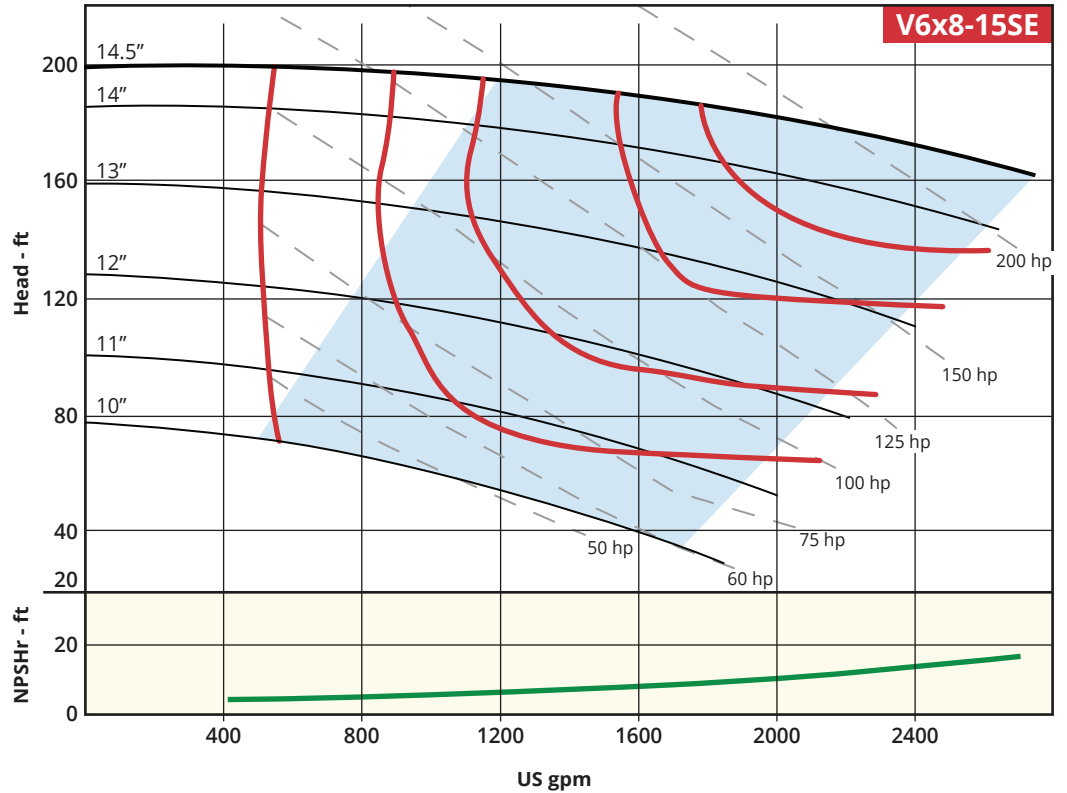

## Dimensions\*

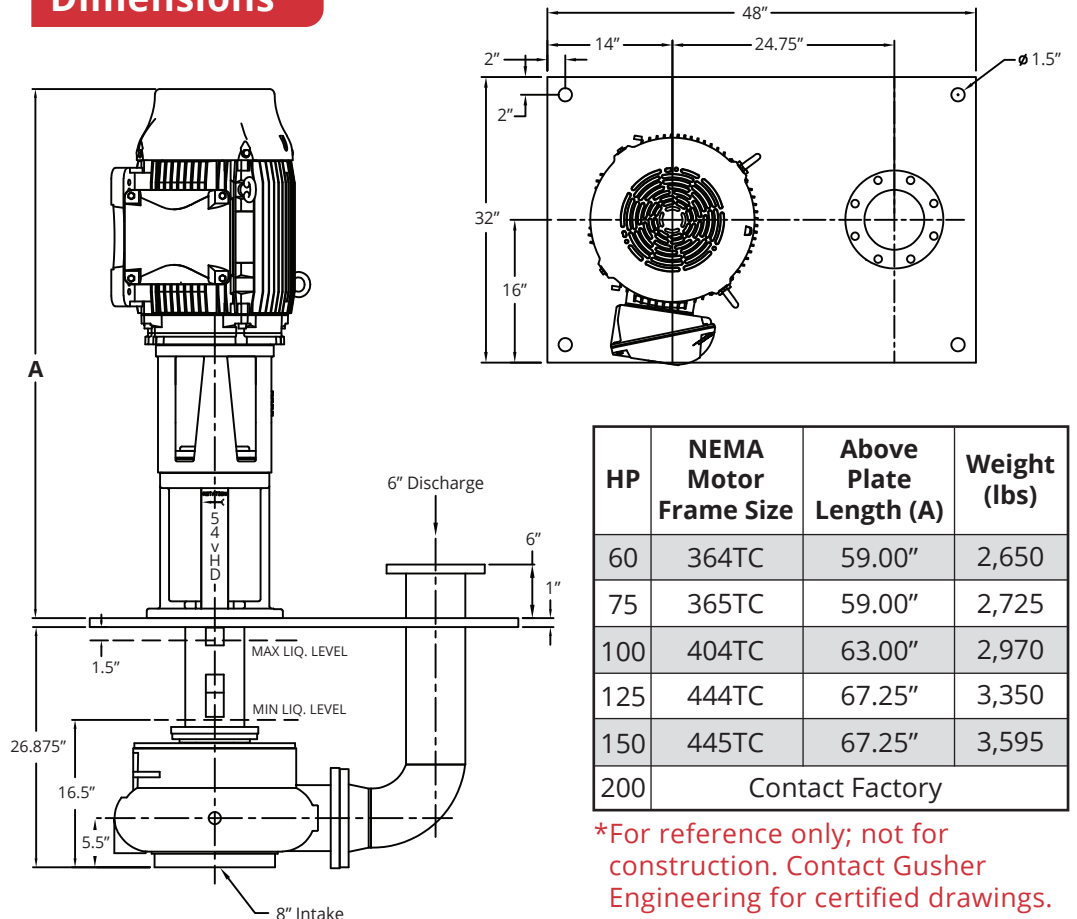

| HP  | NEMA Motor Frame Size | Above Plate Length (A) | Weight (lbs) |
|-----|-----------------------|------------------------|--------------|
| 60  | 364TC                 | 59.00"                 | 2,650        |
| 75  | 365TC                 | 59.00"                 | 2,725        |
| 100 | 404TC                 | 63.00"                 | 2,970        |
| 125 | 444TC                 | 67.25"                 | 3,350        |
| 150 | 445TC                 | 67.25"                 | 3,595        |
| 200 | Contact Factory       |                        |              |

\*For reference only; not for construction. Contact Gusher Engineering for certified drawings.