

A RUTHMAN COMPANY

Vortex Series Horizontal Pumps

VORTEX
V3X4-13SE

1750 RPM

Gusher Vortex Series Horizontal pumps provide years of trouble-free, low maintenance operation in applications with high levels of solids or entrained air.

Vortex pumps handle solids and fibrous materials without clogging. Their design moves liquids and oils containing up to 30% entrained air with no adverse effects on suction performance. Low flows are not a problem for Vortex pumps, as the design allows throttling to a low performance range unacceptable to many centrifugal pumps.

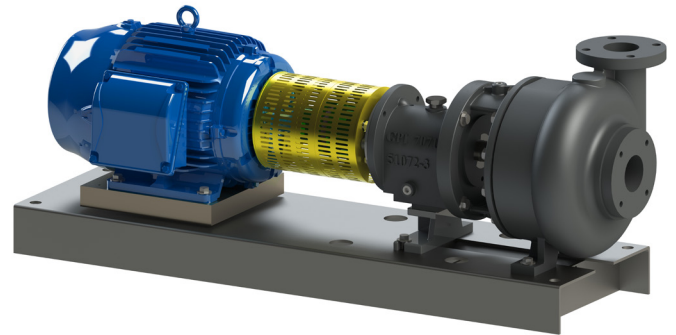

Key Specifications

Type: Vortex Centrifugal End Suction

Flow: Up to 1,150 gpm

Head: Up to 210' TDH

Liquid Temp: Max 180° F

Max Solid Size: 3"

Power Frame: 7071M

Motor Type: TEFC, T Frame

Intake: 4"

Discharge: 3"

Power: 30 hp, 40 hp, 50 hp, 60 hp, 75 hp and 100 hp

Features

- Recessed impeller handles solids and fibrous material without clogging
- Durable CD4MCu impeller standard to prevent premature wear
- Choice of materials for process chemical compatibility
- Renewable shaft sleeve protects shaft from wear
- Mechanical seal prevents leakage
- Back pullout design simplifies maintenance
- VFD compatible motors to suit application needs
- Power frame and spare wear parts interchangeable with Gusher 7071 Series pumps to streamline replacement part inventory

Options

- Cast Iron, Ductile Iron, 316 Stainless Steel, or CD4MCu construction
- Multiple mechanical seal materials
- Flush line addition

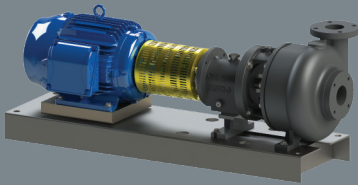

Low Maintenance

- Long service life
- Back pullout design
- Renewable shaft sleeve

Custom Design

- Choice of materials
- Choice of seals

Applications

- Agriculture
- Fibrous Waste
- Sludge
- Shavings
- Swarf
- Paper Pulp
- Wastewater



A RUTHMAN COMPANY

www.Gusher.com
Info@Gusher.com
859.824.5001

Performance Curve

1750 RPM

Recommended Operating Range

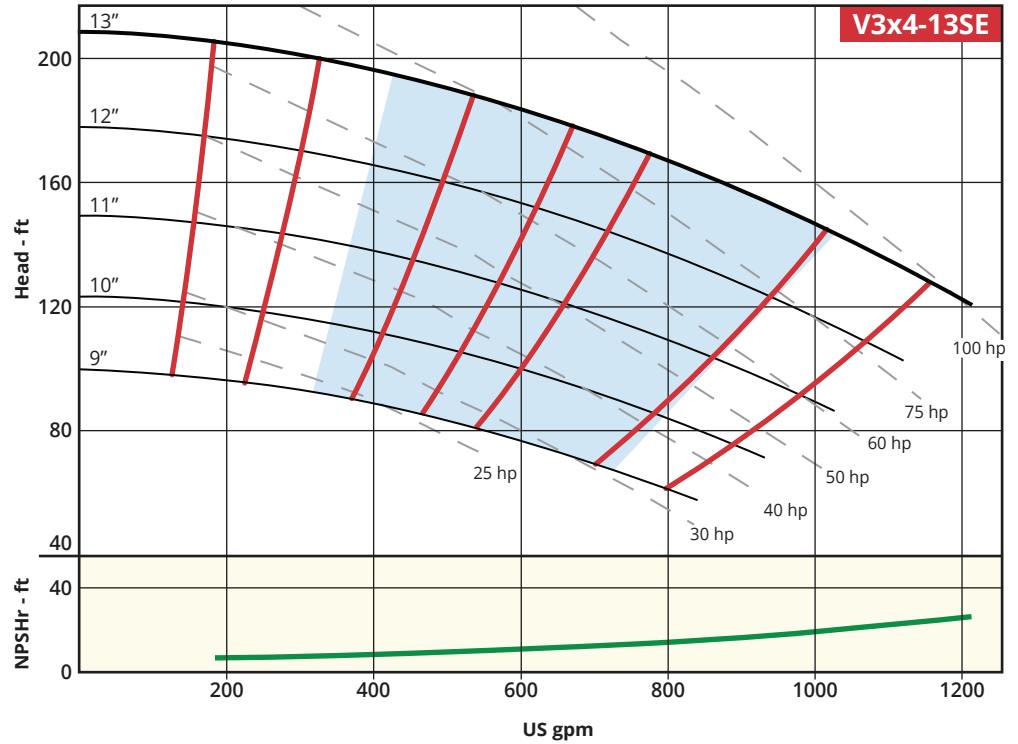

Dimensions*

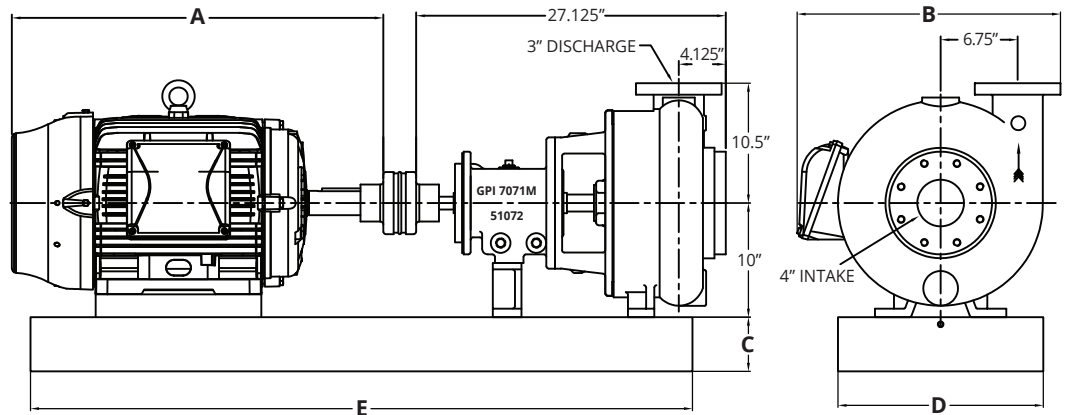

HP	NEMA Motor Frame Size	Base	Motor Length (A)	Conduit Box to Shaft Width (B)	Base Height (C)	Base Width (D)	Base Length (E)	Weight (lbs)
30	286T	67220-3M1	28.00"	21.63"	4.75"	18.00"	58.00"	1,038
40	324T	67220-3M1	31.13"	23.00"	4.75"	18.00"	58.00"	1,160
50	326T	67220-3M1	31.13"	23.00"	4.75"	18.00"	58.00"	1,200
60	364T	67220-3M2	34.50"	25.50"	5.75"	18.00"	58.00"	1,475
75	365T	67220-3M2	34.50"	26.50"	5.75"	18.00"	58.00"	1,538
100	Contact Factory							

*For reference only; not for construction. Contact Gusher Engineering for certified drawings.